



Accelerator Physics

Weak Focusing

S. A. Bogacz, G. A. Krafft, S. DeSilva, I.
Neththikumara

Jefferson Lab

Old Dominion University

Lecture 2

Betatron



25 MeV electron accelerator with its inventor: Don Kerst. The earliest electron accelerators for medical uses were betatrons.

300 MeV ~ 1949

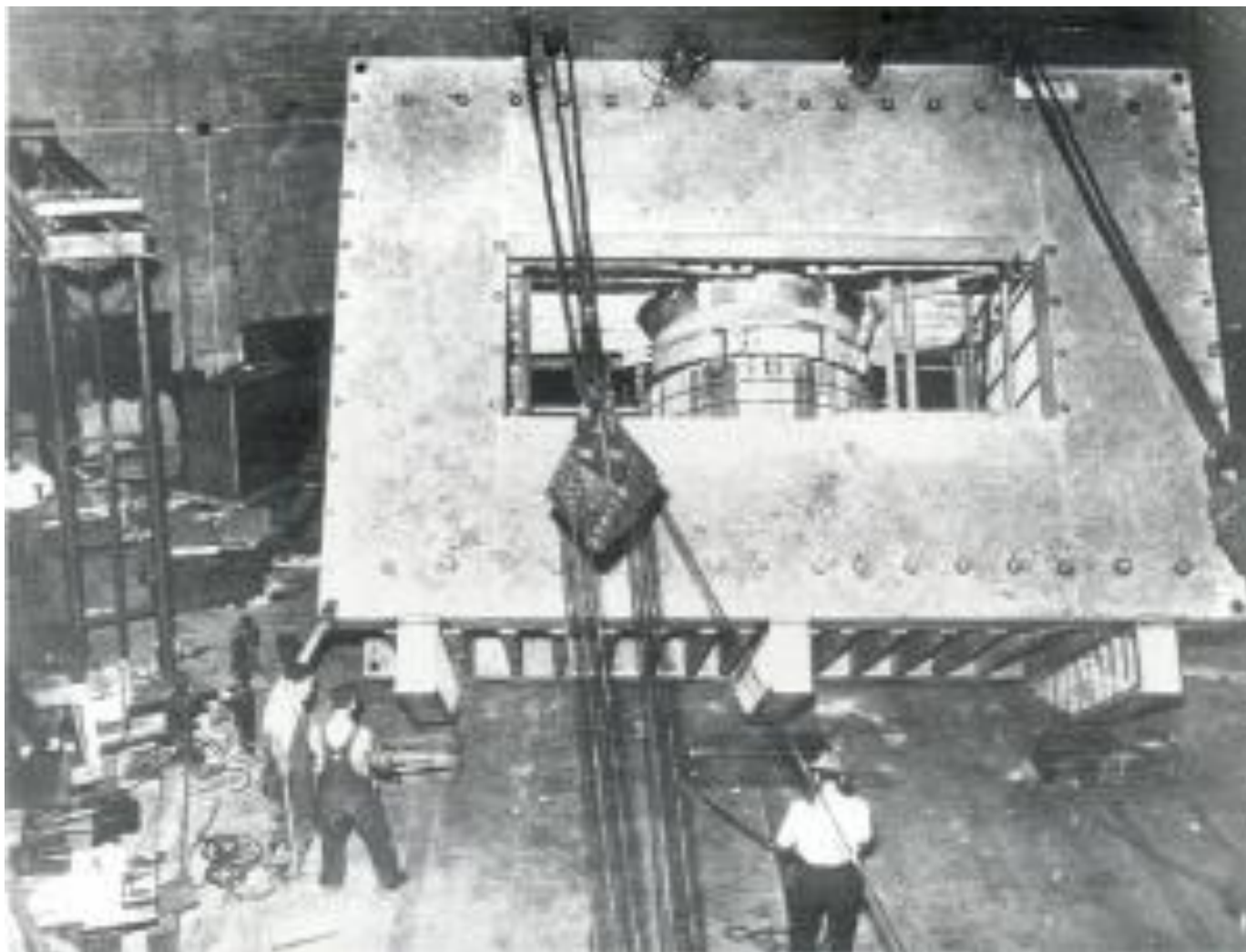

Electromagnetic Induction

Faraday's Law: Differential Form of Maxwell Equation

$$\vec{\nabla} \times \vec{E} = -\frac{\partial \vec{B}}{\partial t}$$

Faraday's Law: Integral Form

$$\oint_S \vec{\nabla} \times \vec{E} \cdot d\vec{S} = -\oint_S \frac{\partial \vec{B}}{\partial t} \cdot d\vec{S}$$

Faraday's Law of Induction

$$\oint_{\partial S} \vec{E} \cdot d\vec{l} = 2\pi R E_\theta = -\frac{d}{dt} \Phi_B$$

Transformer

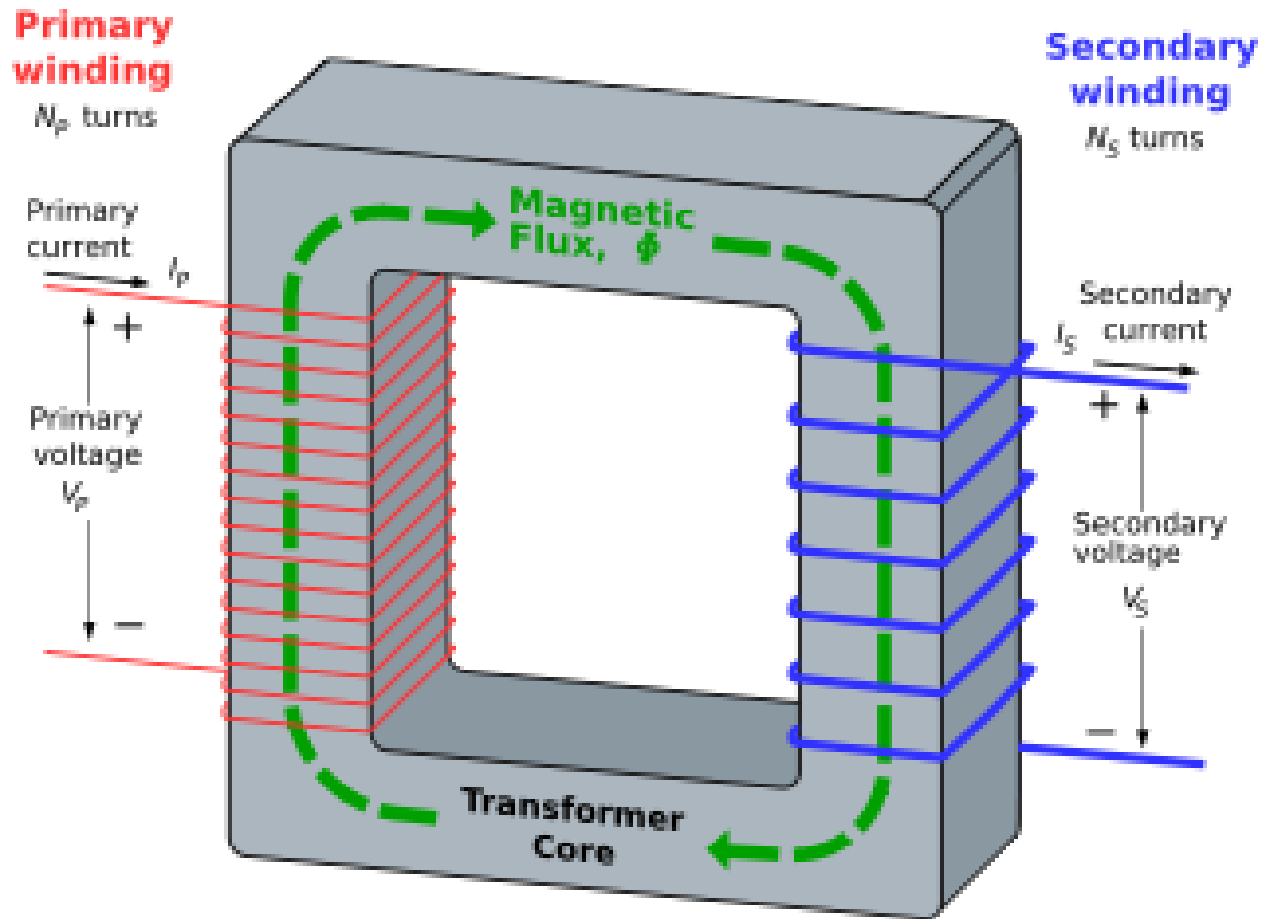

Betatron as a Transformer

- In the betatron the electron beam itself is the secondary winding of the transformer. Energy transferred directly to the electrons

$$2\pi RE_{\theta} = -\frac{d}{dt}\Phi_B$$

- Radial Equilibrium

$$R = \frac{\beta c}{eB / \gamma m}$$

- Energy Gain Equation

$$\frac{d\gamma}{dt} = \frac{eE_{\theta}\beta c}{mc^2}$$

Betatron condition

To get radial stability in the electron beam orbit (i.e., the orbit radius does not change during acceleration and electrons relativistic), need

$$R = \text{const} \approx \frac{\gamma mc}{eB} \rightarrow \frac{e}{mc} = \frac{\gamma}{RB}$$

$$\frac{d\gamma}{dt} \approx \frac{ec}{mc^2} \frac{1}{2\pi R} \frac{d\Phi_B}{dt} \rightarrow \gamma \approx \gamma \frac{\Phi_B}{2\pi R^2 B}$$

$$\therefore \Phi_B = 2\pi R^2 B (r = R)$$

This last expression is sometimes called the “betatron two for one” condition. The energy increase from the flux change is

$$\Delta\gamma \approx \frac{e\beta c}{2\pi R mc^2} \Delta\Phi_B = \frac{eR}{mc} \Delta B (r = R)$$

Two for one in pictures

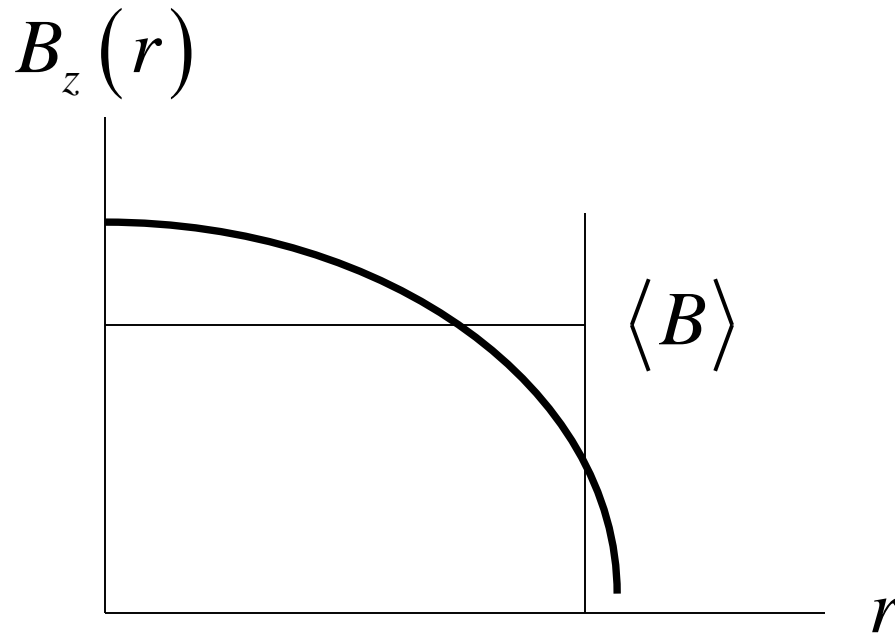

$$\Phi_B = 2\pi \int_0^R B_z(r) r dr \equiv \pi \langle B \rangle R^2 = 2\pi B_z(r=R) R^2$$

$$\rightarrow B_z(r=R) = \frac{1}{2} \frac{\Phi_B}{\pi R^2} = \frac{\langle B \rangle}{2}$$

Transverse Beam Stability

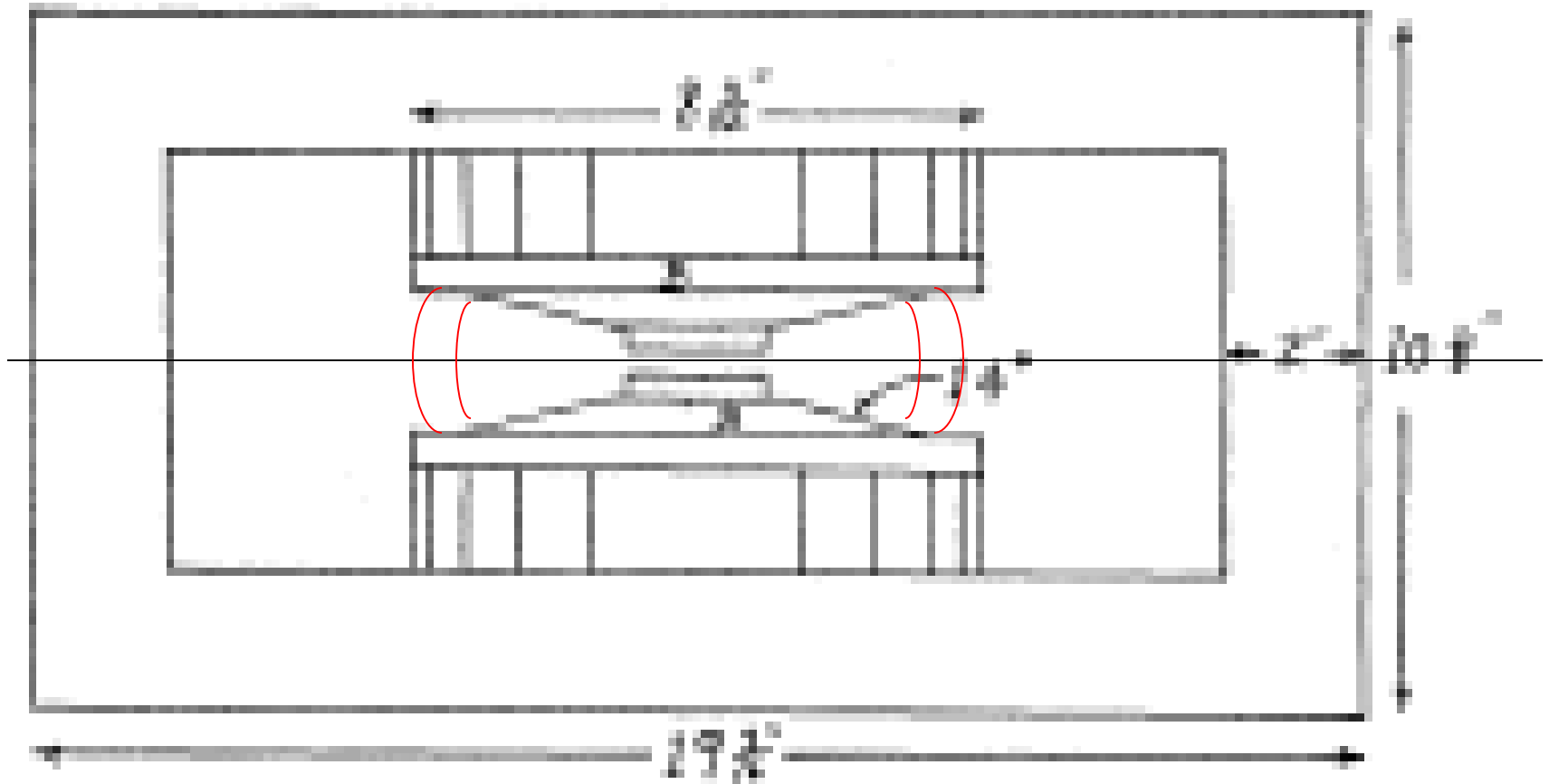

Ensured by proper shaping of the magnetic field in the betatron

Relativistic Equations of Motion

Standard Cylindrical Coordinates

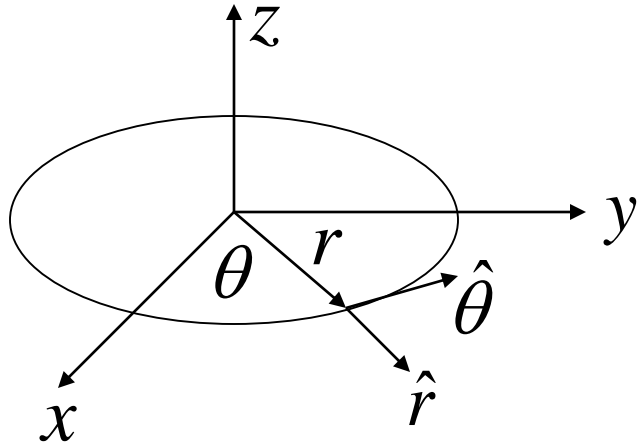

$$\frac{d\vec{v}}{dt} = \frac{q}{\gamma m} (\vec{v} \times \vec{B}) \quad \frac{d\gamma}{dt} = 0!!$$

$$r^2 = x^2 + y^2$$

$$x = r \cos \theta \quad y = r \sin \theta$$

$$\hat{r} = \cos \theta \hat{x} + \sin \theta \hat{y} \quad \hat{\theta} = -\sin \theta \hat{x} + \cos \theta \hat{y}$$

$$v_r = \vec{v} \cdot \hat{r} = \dot{r} \quad v_\theta = \vec{v} \cdot \hat{\theta} = r\dot{\theta}$$

$$\frac{d\vec{v}}{dt} = \frac{d}{dt} (v_r \hat{r} + v_\theta \hat{\theta} + v_z \hat{z})$$

$$d\hat{r} / dt = \dot{\theta} \hat{\theta}$$

$$d\hat{\theta} / dt = -\dot{\theta} \hat{r}$$

Cylindrical Equations of Motion

In components

$$\ddot{r} - r\dot{\theta}^2 = \frac{q}{\gamma m} \left(\vec{v} \times \vec{B} \right)_r = \frac{q}{\gamma m} r\dot{\theta} B_z$$

$$r\ddot{\theta} + 2\dot{r}\dot{\theta} = \frac{q}{\gamma m} \left(\vec{v} \times \vec{B} \right)_\theta = \frac{q}{\gamma m} \left(\dot{z}B_r - \dot{r}B_z \right)$$

$$\ddot{z} = \frac{q}{\gamma m} \left(\vec{v} \times \vec{B} \right)_z = -\frac{q}{\gamma m} r\dot{\theta} B_r$$

Zero'th order solution

$$r(t) = \text{constant} = R \quad \gamma(t) = \text{constant} = \gamma_0$$

$$\theta(t) = \theta_0 + \dot{\theta}_0 t \quad z(t) = 0$$

Magnetic Field Near Orbit

Get cyclotron frequency again, as should

$$\dot{\theta}_0 = -\frac{qB_z(r=R, z=0)}{\gamma_0 m} = \Omega_c$$

Magnetic field near equilibrium orbit

$$\vec{B}(r, z) \approx B_0 \hat{z} + \frac{\partial B_r}{\partial r} (r - R) \hat{r} + \frac{\partial B_z}{\partial r} (r - R) \hat{z} +$$

$$\frac{\partial B_r}{\partial z} z \hat{r} + \frac{\partial B_z}{\partial z} z \hat{z}$$

$$\vec{\nabla} \times \vec{B} = 0 \rightarrow \frac{\partial B_z}{\partial r} = \frac{\partial B_r}{\partial z} \quad \vec{\nabla} \cdot \vec{B} = 0, B_r = 0 \rightarrow \frac{\partial B_z}{\partial z} = 0$$

Field Index

Magnetic Field completely specified by its z -component on the mid-plane

$$\vec{B}(r, z) \approx B_0 \hat{z} + \frac{\partial B_z}{\partial r} \left[(r - R) \hat{z} + z \hat{r} \right]$$

Power Law model for fall-off

$$B_z(r, z = 0) \approx B_0 (R / r)^n$$

The constant n describing the falloff is called the **field index**

$$\vec{B}(r, z) \approx B_0 \hat{z} - \frac{nB_0}{R} \left[(r - R) \hat{z} + z \hat{r} \right]$$

Linearized Equations of Motion

Assume particle orbit “close to” or “nearby” the unperturbed orbit

$$\delta r(t) = r(t) - R \quad \delta\theta(t) = \theta(t) - \Omega_c t \quad \delta z(t) = z(t)$$

$$\gamma = \gamma_0 + \delta\gamma \quad B_z \approx B_0 - \frac{nB_0}{R} \delta r \quad B_r \approx -\frac{nB_0}{R} \delta z$$

$$\delta\ddot{r} - \delta r \Omega_c^2 - 2R\Omega_c \delta\dot{\theta} =$$

$$\frac{q}{\gamma_0 m} \left[\delta r \Omega_c B_0 + R \delta\dot{\theta} B_0 - R \Omega_c \frac{nB_0}{R} \delta r - R \Omega_c B_0 \frac{\delta\gamma}{\gamma_0} \right]$$

$$R\delta\ddot{\theta} + 2\delta\dot{r}\Omega_c = \delta\dot{r}\Omega_c \rightarrow R\delta\dot{\theta} + \delta r\Omega_c = \text{const}$$

$$\delta\ddot{z} = \frac{q}{\gamma_0 m} R \Omega_c \frac{nB_0}{R} \delta z = -n\Omega_c^2 \delta z$$

“Weak” Focusing

For small deviations from the unperturbed circular orbit the transverse deviations solve the (driven!) harmonic oscillator equations

$$\delta \ddot{r} + (1 - n) \Omega_c^2 \delta r = \Omega_c \text{const} + R \Omega_c^2 (\delta \gamma / \gamma_0)$$

$$\delta \ddot{z} + n \Omega_c^2 \delta z = 0$$

The small deviations oscillate with a frequency $n^{1/2} \Omega_c$ in the vertical direction and $(1 - n)^{1/2} \Omega_c$ in the radial direction.

Focusing by magnetic field shaping of this sort is called **Weak Focusing**. This method was the primary method of focusing in accelerators up until the mid 1950s, and is still occasionally used today.

Stability of Transverse Oscillations



- For long term stability, the field index must satisfy

$$0 < n < 1$$

because only then do the transverse oscillations remain bounded for all time. Because transverse oscillations in accelerators were theoretically studied by Kerst and Serber (*Physical Review*, **60**, 53 (1941)) for the first time in betatrons, transverse oscillations in accelerators are known generically as **betatron oscillations**. Typically n was about 0.6 in betatrons.

Physical Source of Focusing

$$0 < n$$

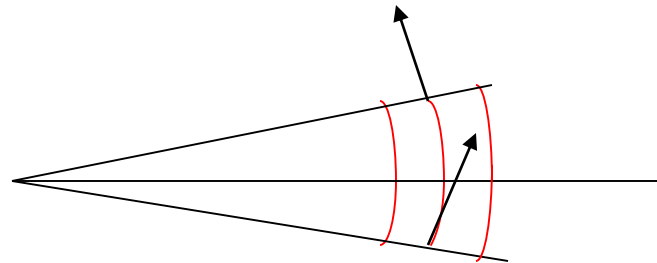

B_r changes sign as go through mid-plane. B_z weaker as r increases

\odot v_θ (for positive charge)

$$n < 1$$

Bending on a circular orbit is naturally focusing in the bend direction (why?!), and accounts for the 1 in $1 - n$. Magnetic field gradient that causes focusing in z causes defocusing in r , essentially because $\partial B_z / \partial r = \partial B_r / \partial z$. For $n > 1$, the defocusing wins out.

First Look at Dispersion

Newton's Prism Experiment

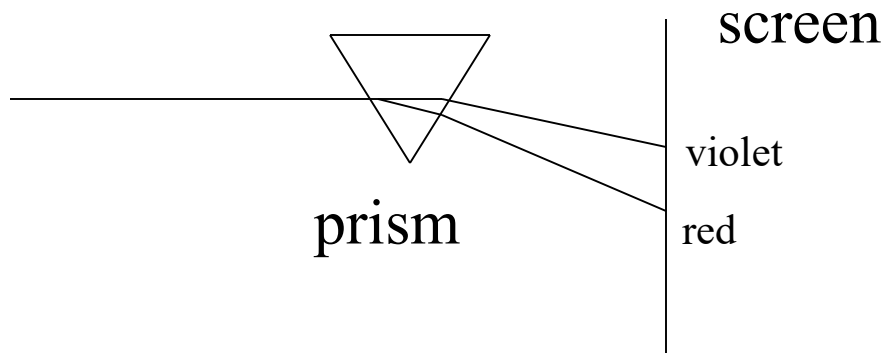

$$\Delta x = D \left(\frac{\Delta p}{p} \right)$$

$$\Delta x = \eta \left(\frac{\Delta p}{p} \right)$$

Dispersion units: m

Bend Magnet as Energy Spectrometer

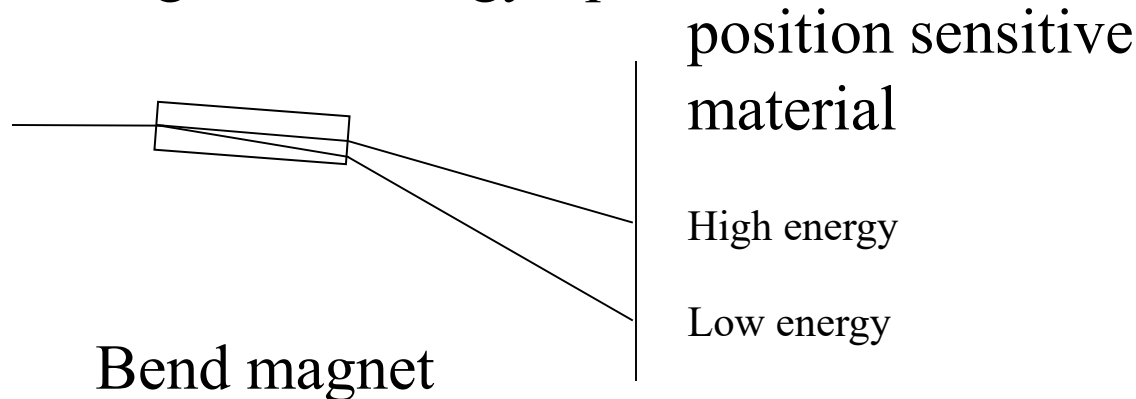

Dispersion for Betatron

Radial Equilibrium

$$R = \frac{\beta c}{eB / \gamma m} = \frac{p}{eB}$$

Linearized

$$(R + \Delta R)(B_0 + \Delta B) = \frac{p + \Delta p}{e} \approx RB_0 + R\Delta B + \Delta RB_0$$

$$\frac{\Delta p}{e} \approx -n\Delta RB_0 + \Delta RB_0 = (1 - n)\Delta RB_0$$

$$\frac{\Delta p}{p} \approx (1 - n) \frac{\Delta R}{R} \rightarrow D_{radial} = \frac{R}{(1 - n)}$$

Evaluate the constant

$$\delta \ddot{r} + (1-n)\Omega_c^2 \delta r = \Omega_c \text{const} + R\Omega_c^2 (\delta\gamma / \gamma_0)$$

For a time independent solution $\delta r = \Delta R$ (orbit at larger radius)

$$(1-n)\Omega_c^2 \Delta R = \Omega_c \text{const} + R\Omega_c^2 (\delta\gamma / \gamma_0) = \Omega_c^2 R \frac{\Delta p}{p}$$

$$\text{const} = \Omega_c R \frac{\Delta p}{p} - \Omega_c R \frac{\delta\gamma}{\gamma_0} = \Omega_c R (1 - \beta_0^2) \frac{\Delta p}{p}$$

General Betatron Oscillation equations

$$\delta \ddot{r} + (1-n)\Omega_c^2 \delta r = \Omega_c^2 R \frac{\Delta p}{p}$$

$$\delta \ddot{z} + n\Omega_c^2 \delta z = 0$$

No Longitudinal Focusing

$$R\delta\dot{\theta} + \Omega_c \delta r = \Omega_c R \frac{\Delta p}{p} (1 - \beta_0^2)$$

$$\theta = \theta_0 + \Omega_c t + \int \left[\Omega_c \frac{\Delta p}{p} \frac{1}{\gamma_0^2} - \Omega_c \frac{\Delta R}{R} \right] dt$$

$$= \theta_0 + \Omega_c t + \int \Omega_c \frac{\Delta p}{p} \left[\frac{1}{\gamma_0^2} - \frac{1}{1-n} \right] dt$$

Speed
Change

Path increase from
displaced orbit

Classical Microtron: Veksler (1945)

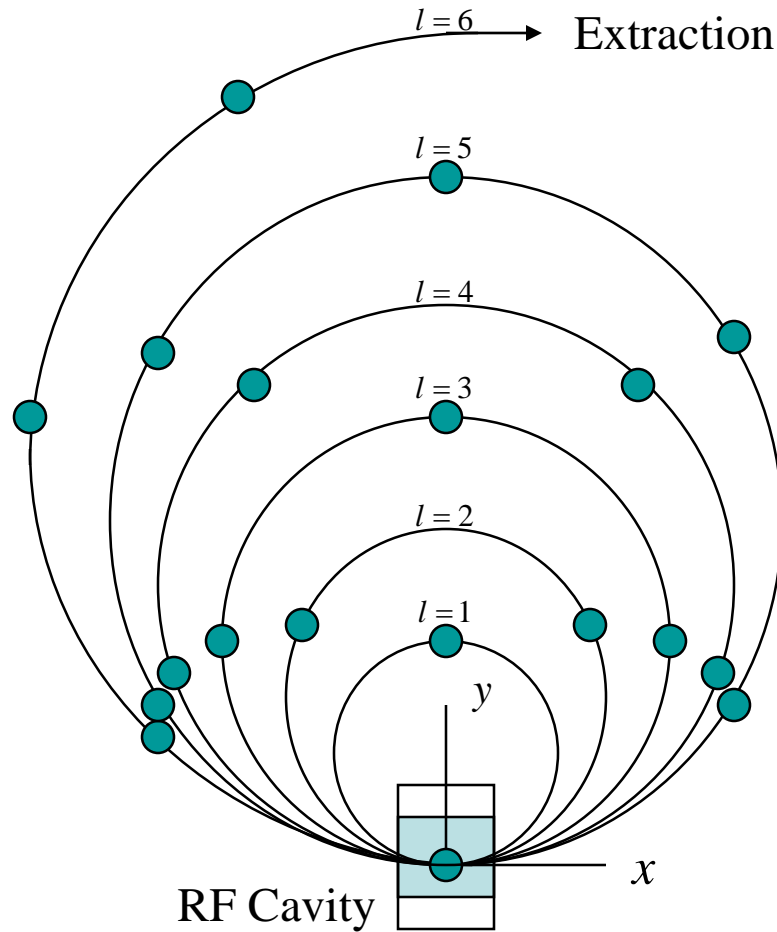

⊗ Magnetic Field

$$\mu = 2$$

$$\nu = 1$$

Basic Principles

For the geometry given

$$\frac{d(\gamma m \vec{v})}{dt} = -e \left[\vec{E} + \vec{v} \times \vec{B} \right]$$

$$\frac{d(\gamma m v_x)}{dt} = e v_y B_z$$

$$\frac{d(\gamma m v_y)}{dt} = -e v_x B_z$$

$$\frac{d^2 v_x}{dt^2} + \Omega_c^2 v_x = 0$$

$$\frac{d^2 v_y}{dt^2} + \Omega_c^2 v_y = 0$$

For each orbit, separately, and exactly

$$v_x(t) = -v_{x0} \cos(\Omega_c t)$$

$$v_y(t) = v_{x0} \sin(\Omega_c t)$$

$$x(t) = -\frac{v_{x0}}{\Omega_c} \sin(\Omega_c t)$$

$$y(t) = \frac{v_{x0}}{\Omega_c} - \frac{v_{x0}}{\Omega_c} \cos(\Omega_c t)$$

Non-relativistic cyclotron frequency: $2\pi f_c = eB_z / m$

Relativistic cyclotron frequency: $\Omega_c = eB / \gamma m$

Bend radius of each orbit is: $\rho_l = v_{x0,l} / \Omega_c \rightarrow c / \Omega_c$

In a conventional cyclotron, the particles move in a circular orbit that grows in size with energy, but where the relatively heavy particles stay in resonance with the RF, which drives the accelerating DEEs at the non-relativistic cyclotron frequency. By contrast, a microtron uses the “other side” of the cyclotron frequency formula. The cyclotron frequency decreases, proportional to energy, and the beam orbit radius increases in each orbit by precisely the amount which leads to arrival of the particles in the succeeding orbits precisely in phase.

Microtron Resonance Condition

Must have that the bunch pattern repeat in time. This condition is only possible if the time it takes to go around each orbit is precisely an integral number of RF periods

$$\gamma_1 = \mu \frac{f_c}{f_{RF}}$$

First Orbit

For classical microtron
assume can inject so that

$$\Delta\gamma = \nu \frac{f_c}{f_{RF}}$$

Each Subsequent
Orbit

$$\gamma_1 \approx 1 + \nu \frac{f_c}{f_{RF}}$$

$$\frac{f_c}{f_{RF}} \approx \frac{1}{\mu - \nu}$$

Parameter Choices

The energy gain in each pass must be identical for this resonance to be achieved, because once f_c/f_{RF} is chosen, $\Delta\gamma$ is fixed. Because the energy gain of non-relativistic ions from an RF cavity IS energy dependent, there is no way (presently!) to make a classical microtron for ions. For the same reason, in electron microtrons one would like the electrons close to relativistic after the first acceleration step. Concern about injection conditions which, as here in the microtron case, will be a recurring theme in examples!

$$f_c / f_{RF} = B_z / B_0 \qquad B_0 = \frac{2\pi mc}{\lambda e}$$

$$B_0 = 0.107 \text{ T} = 1.07 \text{ kG} @ 10 \text{ cm}$$

Notice that this field strength is NOT state-of-the-art, and that one normally chooses the magnetic field to be around this value. High frequency RF is expensive too!

Classical Microtron Possibilities

Assumption: Beam injected at low energy and energy gain is the same for each pass

$\frac{f_c}{f_{RF}}$	1	1/2	1/3	1/4	
	$\mu, \nu, \gamma_1, \Delta\gamma$	$\mu, \nu, \gamma_1, \Delta\gamma$	$\mu, \nu, \gamma_1, \Delta\gamma$	$\mu, \nu, \gamma_1, \Delta\gamma$...
	2, 1, 2, 1	3, 1, 3/2, 1/2	4, 1, 4/3, 1/3	5, 1, 5/4, 1/4	...
	3, 2, 3, 2	4, 2, 2, 1	5, 2, 5/3, 2/3	6, 2, 3/2, 1/2	...
	4, 3, 4, 3	5, 3, 5/2, 3/2	6, 3, 2, 1	7, 3, 7/4, 3/4	...
	5, 4, 5, 4	6, 4, 3, 2	7, 4, 7/3, 4/3	8, 4, 2, 1	...
	⋮	⋮	⋮	⋮	⋮

← B bigger

$\Delta\gamma$ lower ↑

For same microtron magnet, no advantage to higher ν ; RF is more expensive because energy per pass needs to be higher

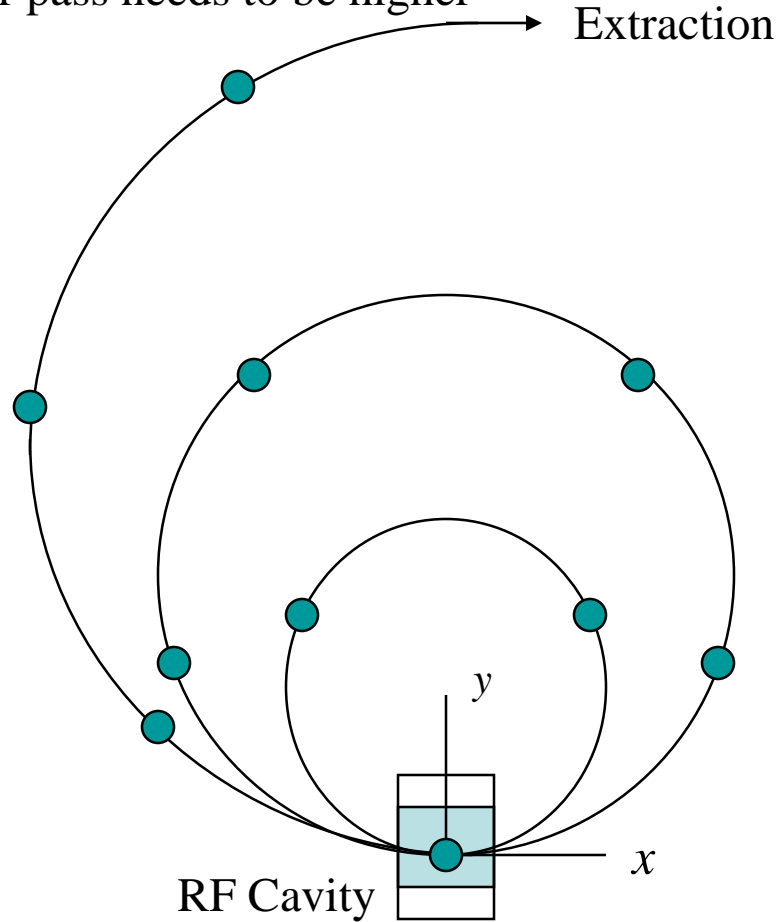

⊗ Magnetic Field

$$\mu = 3$$
$$\nu = 2$$

Going up diagonal increases frequency

To deal with lower frequencies, go up the diagonal

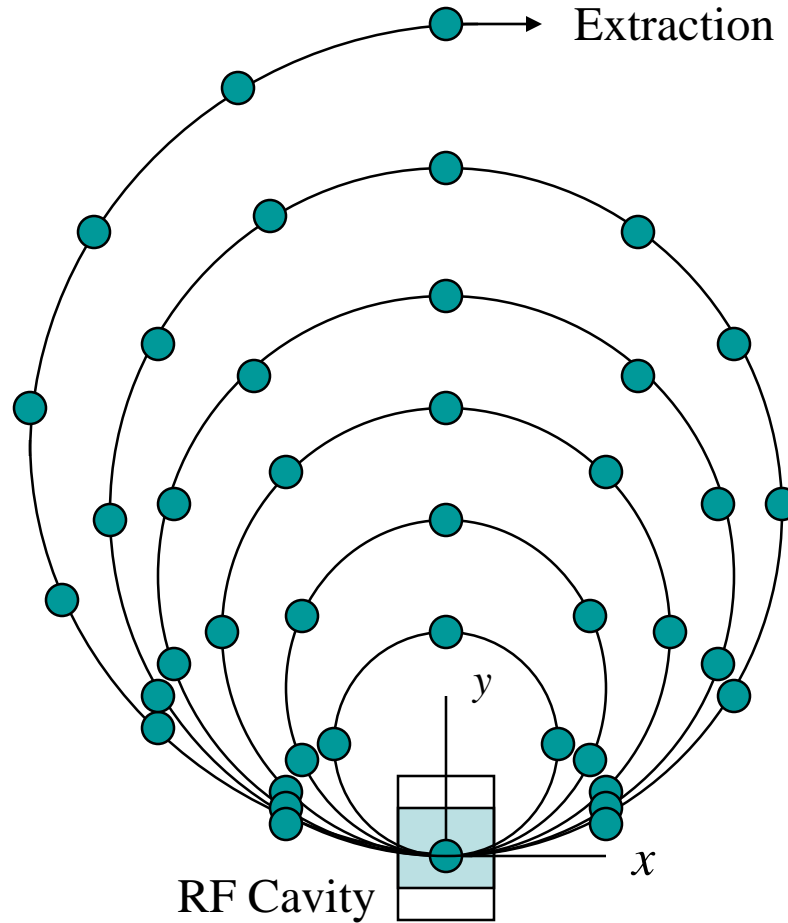

⊗ Magnetic Field

$$\mu = 4$$

$$\nu = 2$$

Phase Stability

Invented independently by Veksler (for microtrons!) and McMillan

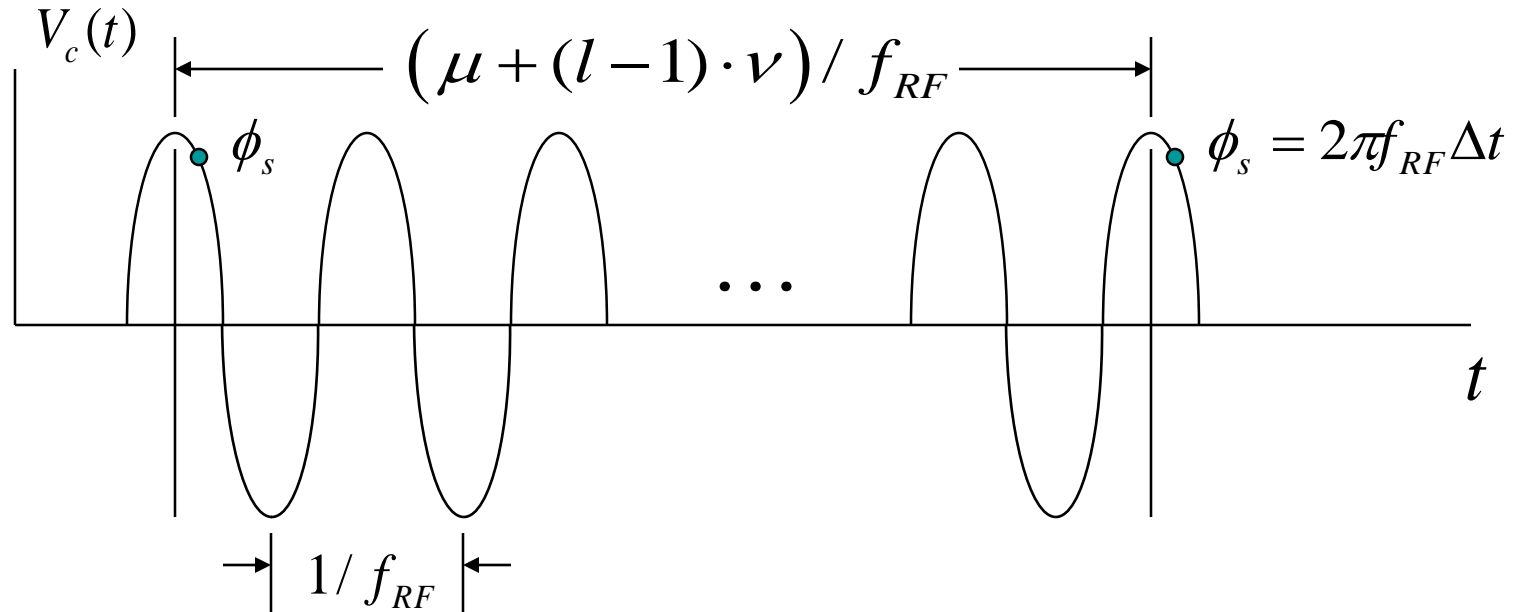

Electrons arriving EARLY get more energy, have a longer path, and arrive later on the next pass. Extremely important discovery in accelerator physics. McMillan used same idea to design first electron synchrotron.

Generic Modern Synchrotron

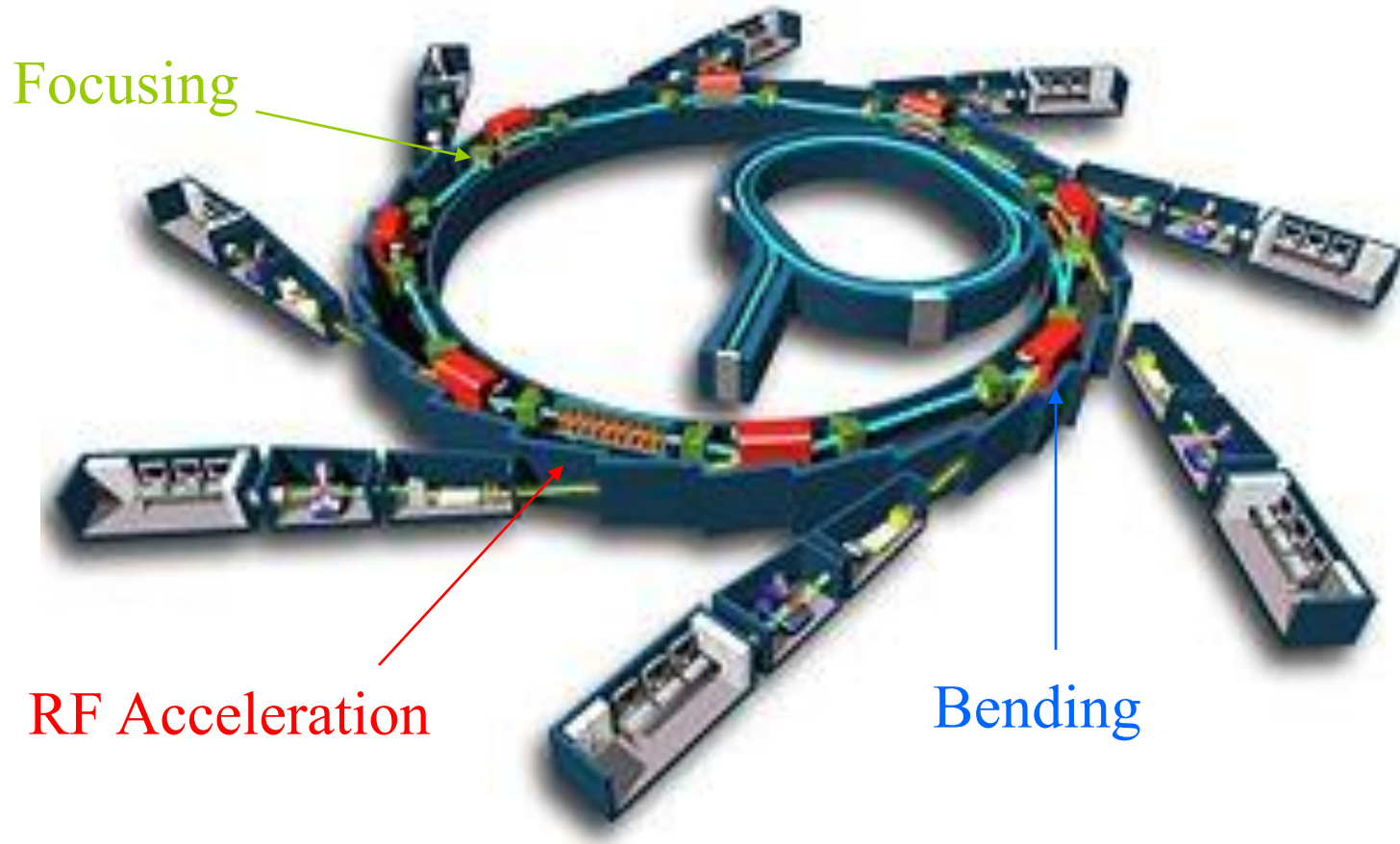

Spokes are user stations for this X-ray ring source

Synchrotron Phase Stability

Edwin McMillan discovered phase stability independently of Veksler and used the idea to design first large electron synchrotron.

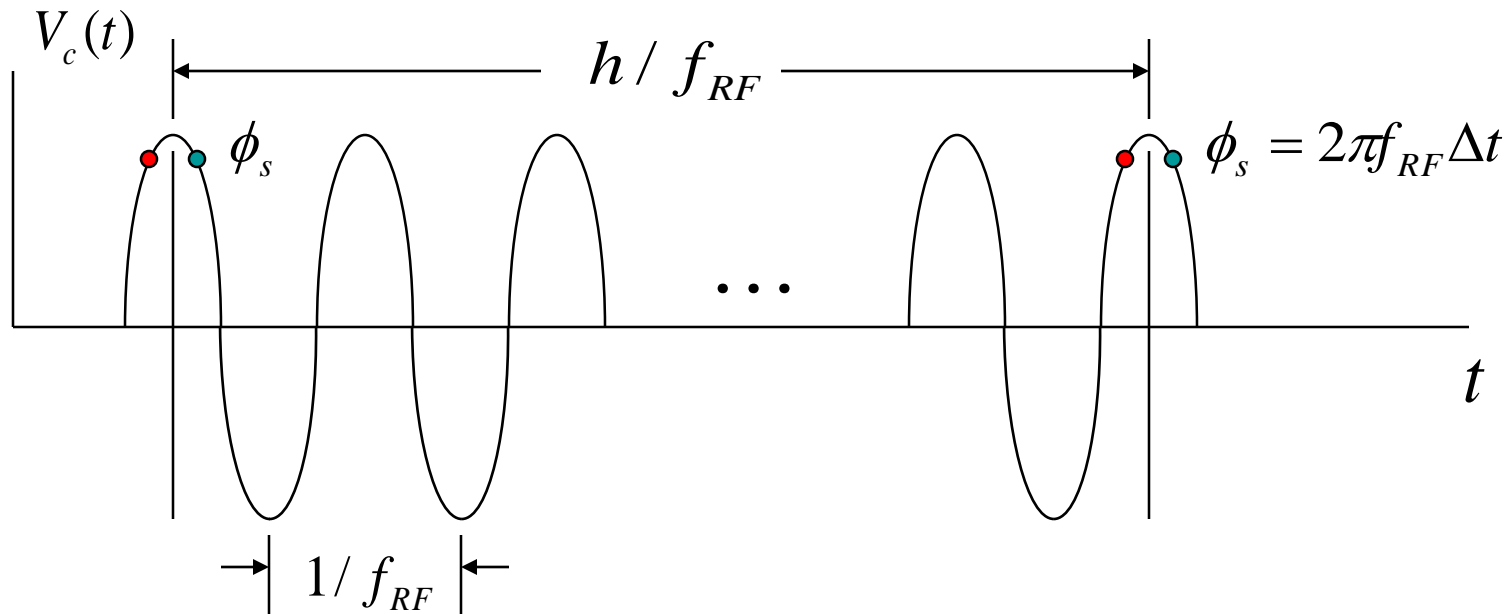

$$h = Lf_{RF} / \beta c$$

Harmonic number: # of RF oscillations in a revolution

Transition Energy

Beam energy where speed increment effect balances path length change effect on accelerator revolution frequency. Revolution frequency independent of beam energy to linear order. We will calculate in a few lecture

- Below Transition Energy: Particles arriving EARLY get less acceleration and speed increment, and arrive later, with respect to the center of the bunch, on the next pass. Applies to heavy particle synchrotrons during first part of acceleration when the beam is non-relativistic and accelerations still produce velocity changes.
- Above Transition Energy: Particles arriving EARLY get more energy, have a longer path, and arrive later on the next pass. Applies for electron synchrotrons and heavy particle synchrotrons when approach relativistic velocities. As noted already, Microtrons operate here.

Ed McMillan



Vacuum chamber for
electron synchrotron
being packed for shipment
to Smithsonian

Full Electron Synchrotron



GE Electron Synchrotron

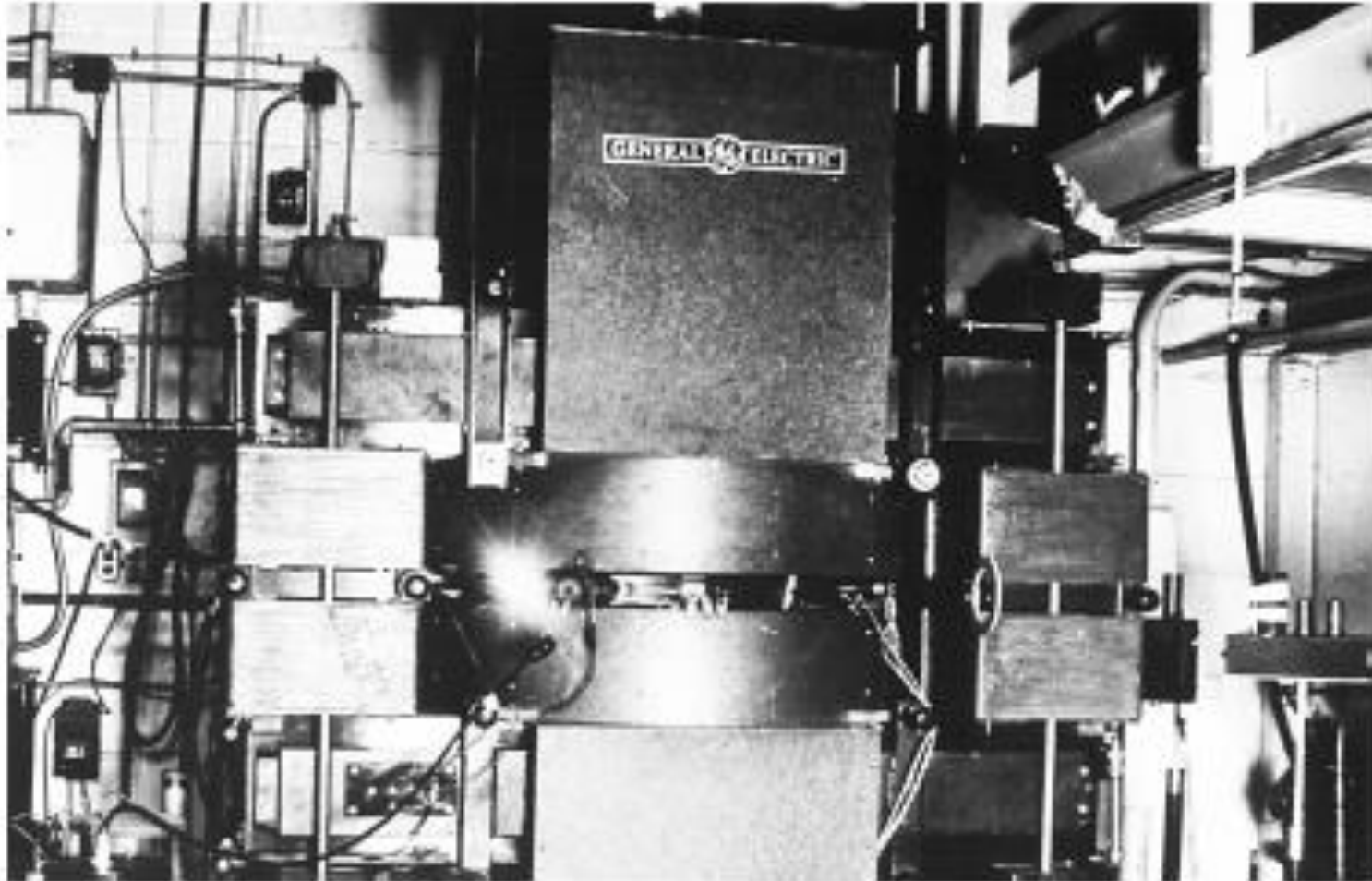

Elder, F. R.; Gurewitsch, A. M.; Langmuir, R. V.; Pollock, H. C., "[Radiation from Electrons in a Synchrotron](#)" (1947) *Physical Review*, vol. 71, Issue 11, pp. 829-830

Cosmotron (First GeV Accelerator)

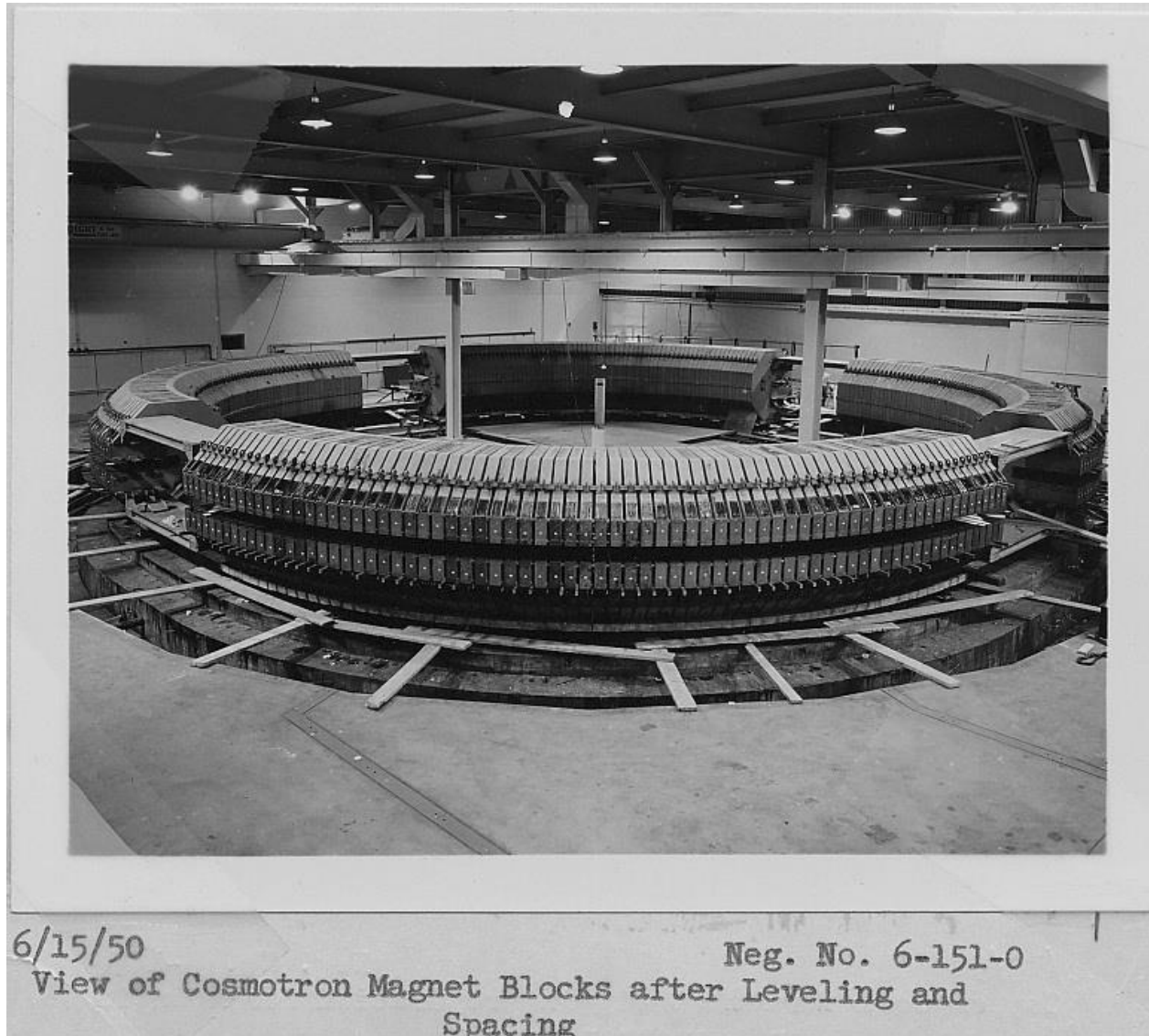

BNL Cosmotron and Shielding

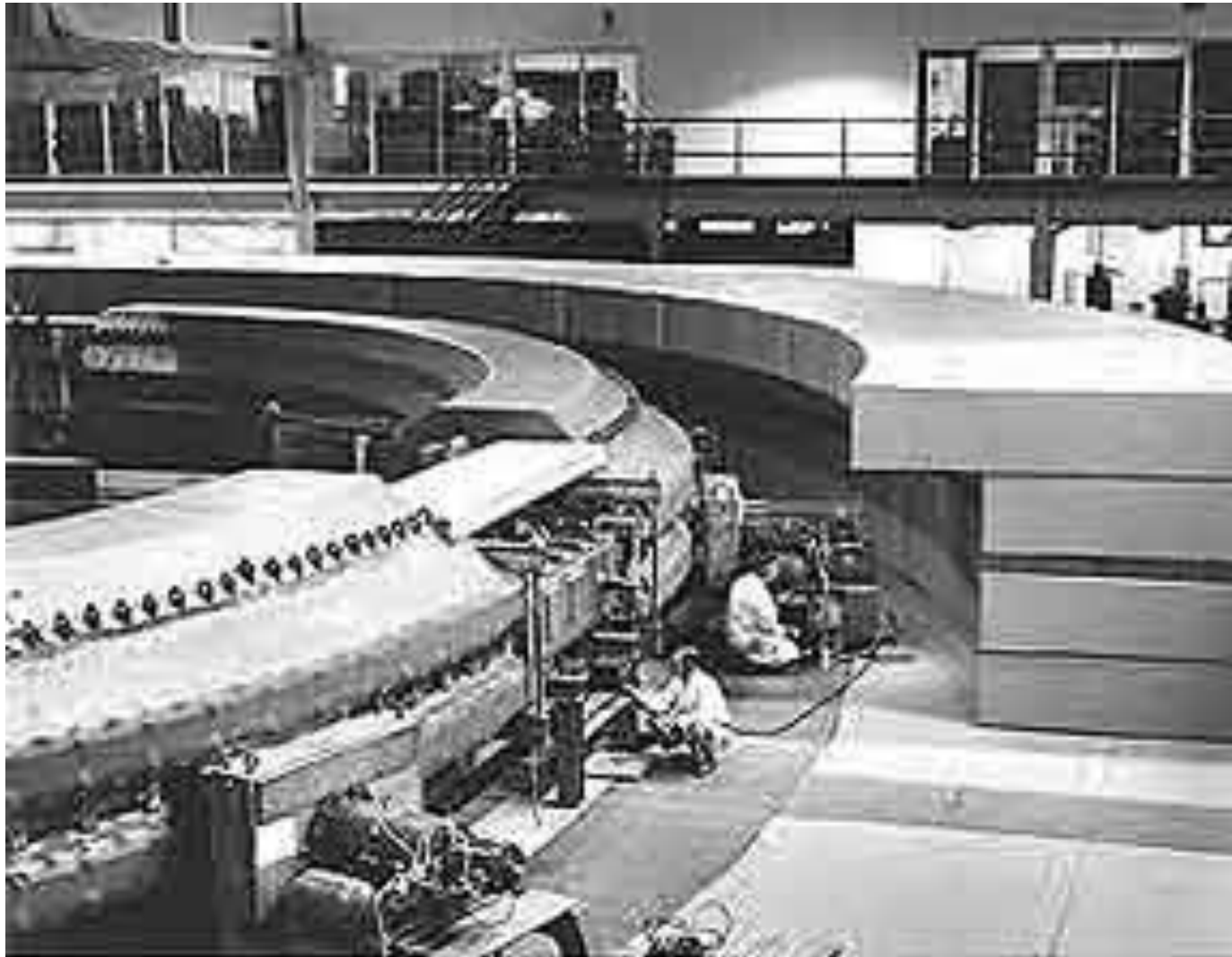

Cosmotron Magnet

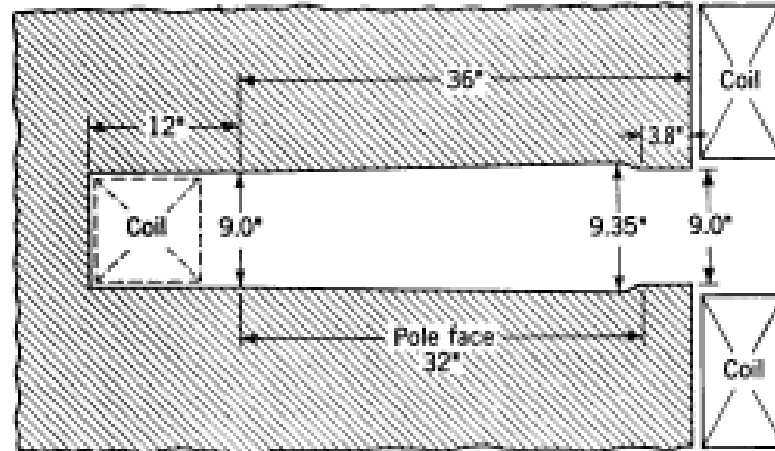

The Cosmotron magnet



Cosmotron People



E. Courant - Lattice Designer



Stan Livingston - Boss



Snyder - theorist



Christofilos - inventor

Bevatron



Designed to discover the antiproton; Largest Weak Focusing Synchrotron

Strong Focusing

- Betatron oscillation work has showed us that, apart from bend plane focusing, a shaped field that focuses in one transverse direction, defocuses in the other
- Question: is it possible to develop a system that focuses in both directions simultaneously?
- Strong focusing: alternate the signs of focusing and defocusing: **get net focusing!!**

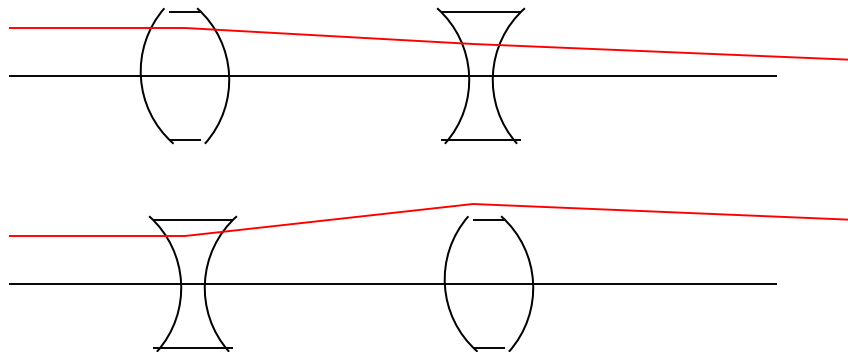

Order doesn't matter

Linear Magnetic Lenses: Quadrupoles



Source: Danfysik Web site

Comment on Strong Focusing

One main advantage of strong focusing. In weak focusing machines, $n < 1$ for stability. Therefore, the fall-off distance, or field gradient cannot be too high. **There is no such limit for strong focusing.**

$$n \gg 1$$

is now allowed, leading to large field gradients and relatively short focal length magnetic lenses. This tighter focusing is what allows smaller beam sizes. Focusing gradients now limited only by magnet construction issues (pole magnetic field limits).

Weak vs. Strong Benders

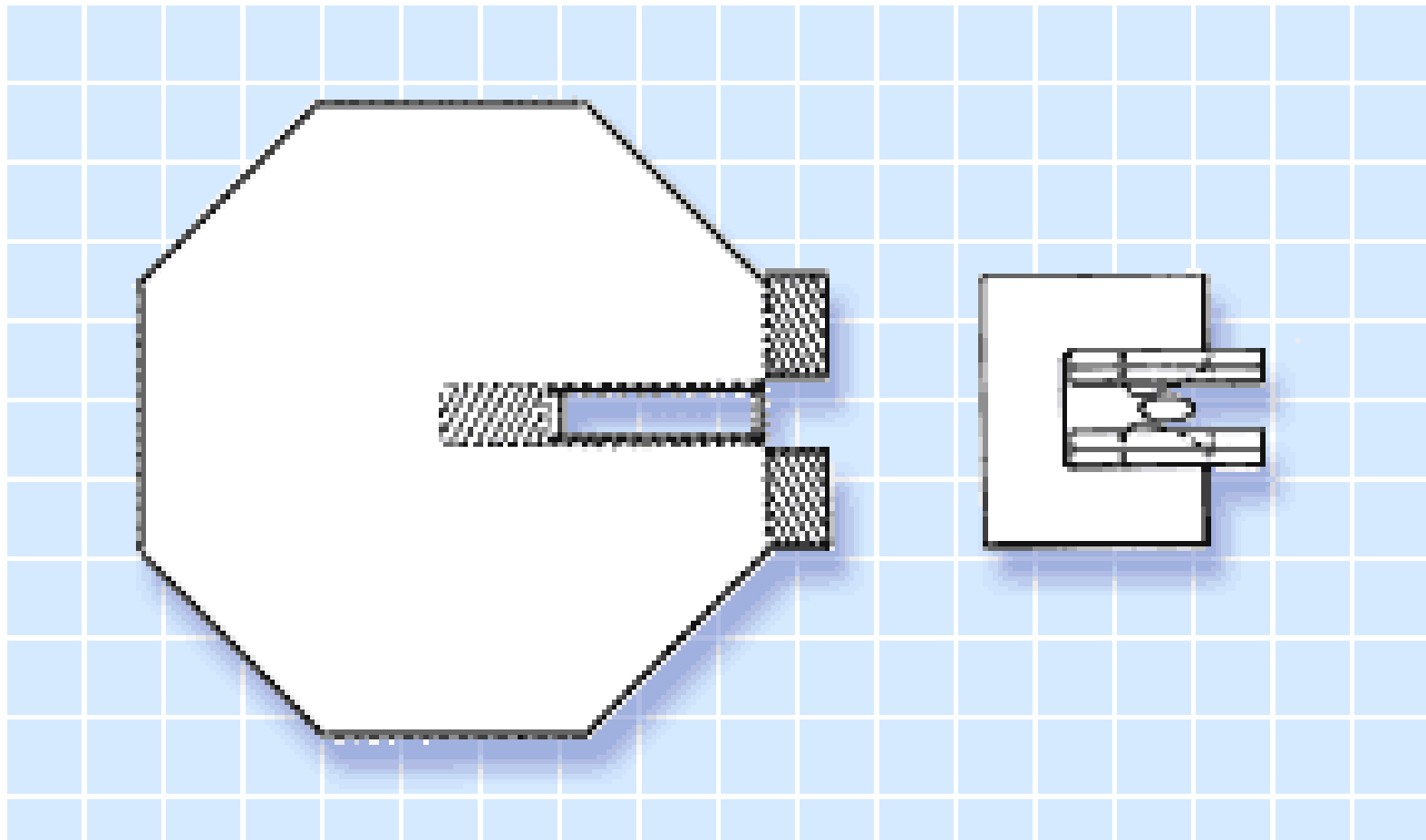

First Strong-Focusing Synchrotron



Cornell 1 GeV Electron Synchrotron (LEPP-AP Home Page)

Alternating Gradient Synchrotron (AGS)



CERN PS

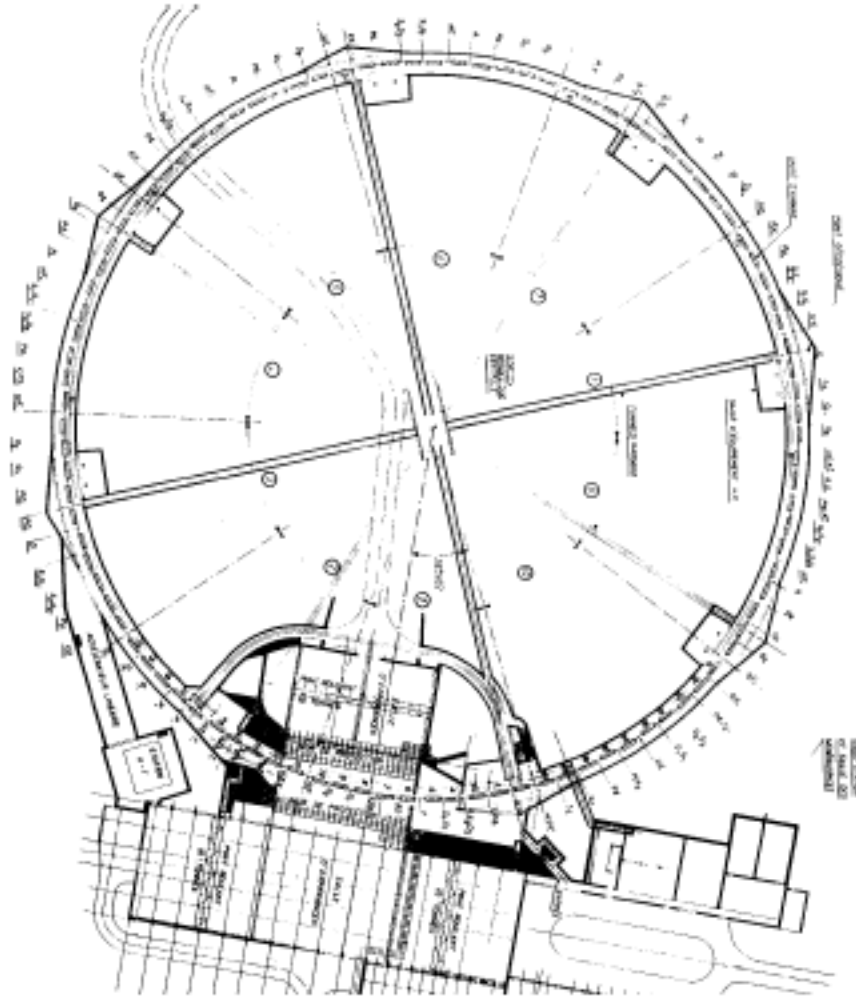

25 GeV Proton Synchrotron

CERN SPS



Eventually 400 GeV protons and antiprotons

FNAL



First TeV-scale accelerator; Large Superconducting Benders

LEP Tunnel (Now LHC!)



Empty



LHC

Storage Rings

- Some modern accelerators are designed not to “accelerate” much at all, but to “store” beams for long periods of time that can be usefully used by experimental users.
 - Colliders for High Energy Physics. Accelerated beam-accelerated beam collisions are much more energetic than accelerated beam-target collisions. To get to the highest beam energy for a given acceleration system design a collider
 - Electron storage rings for X-ray production: circulating electrons emit synchrotron radiation for a wide variety of experimental purposes.

Princeton-Stanford Collider



Princeton-Stanford CBX - 1961



SPEAR

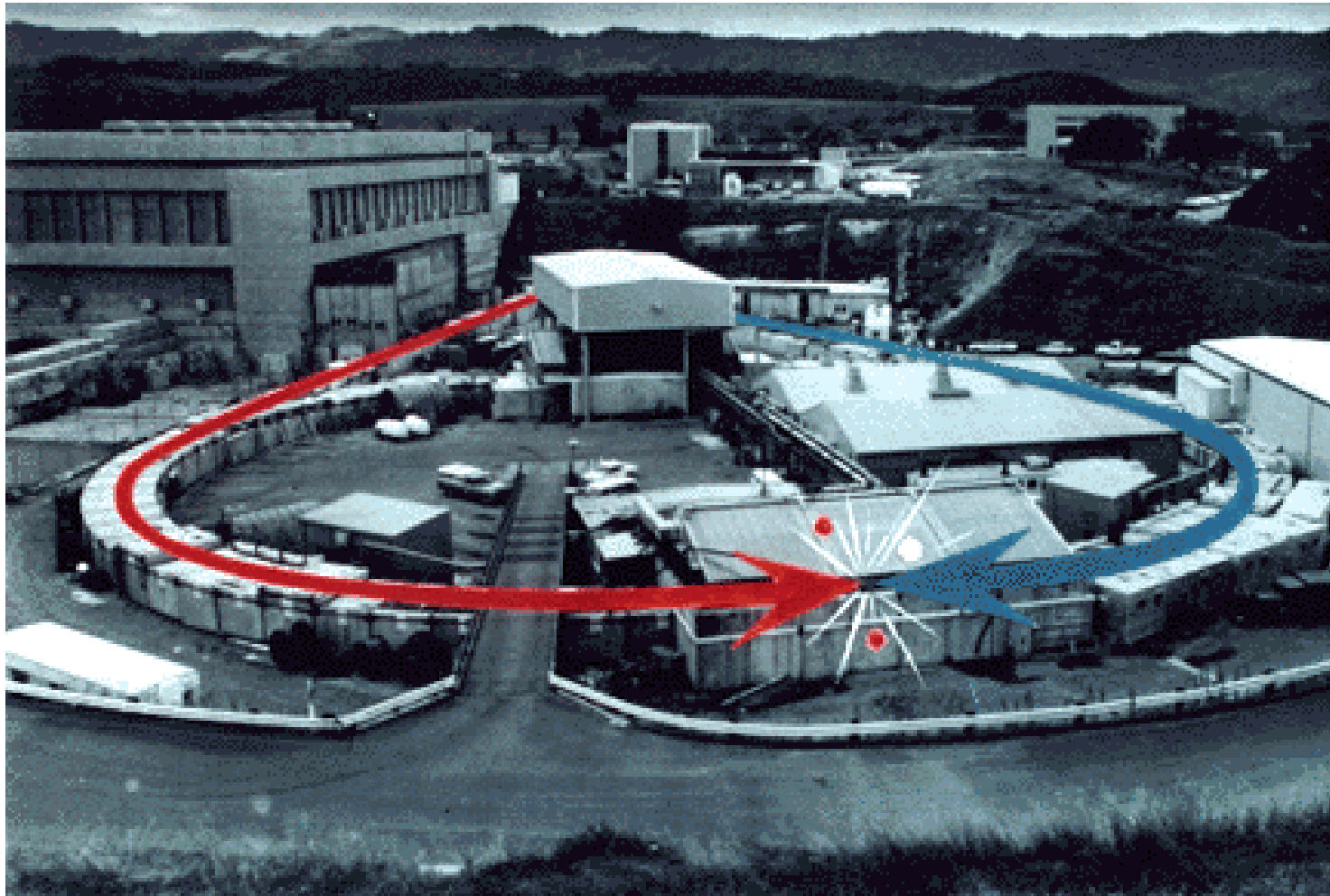

Eventually became leading synchrotron radiation machine

Cornell 10 GeV ES and CESR



SLAC's PEP II B-factory

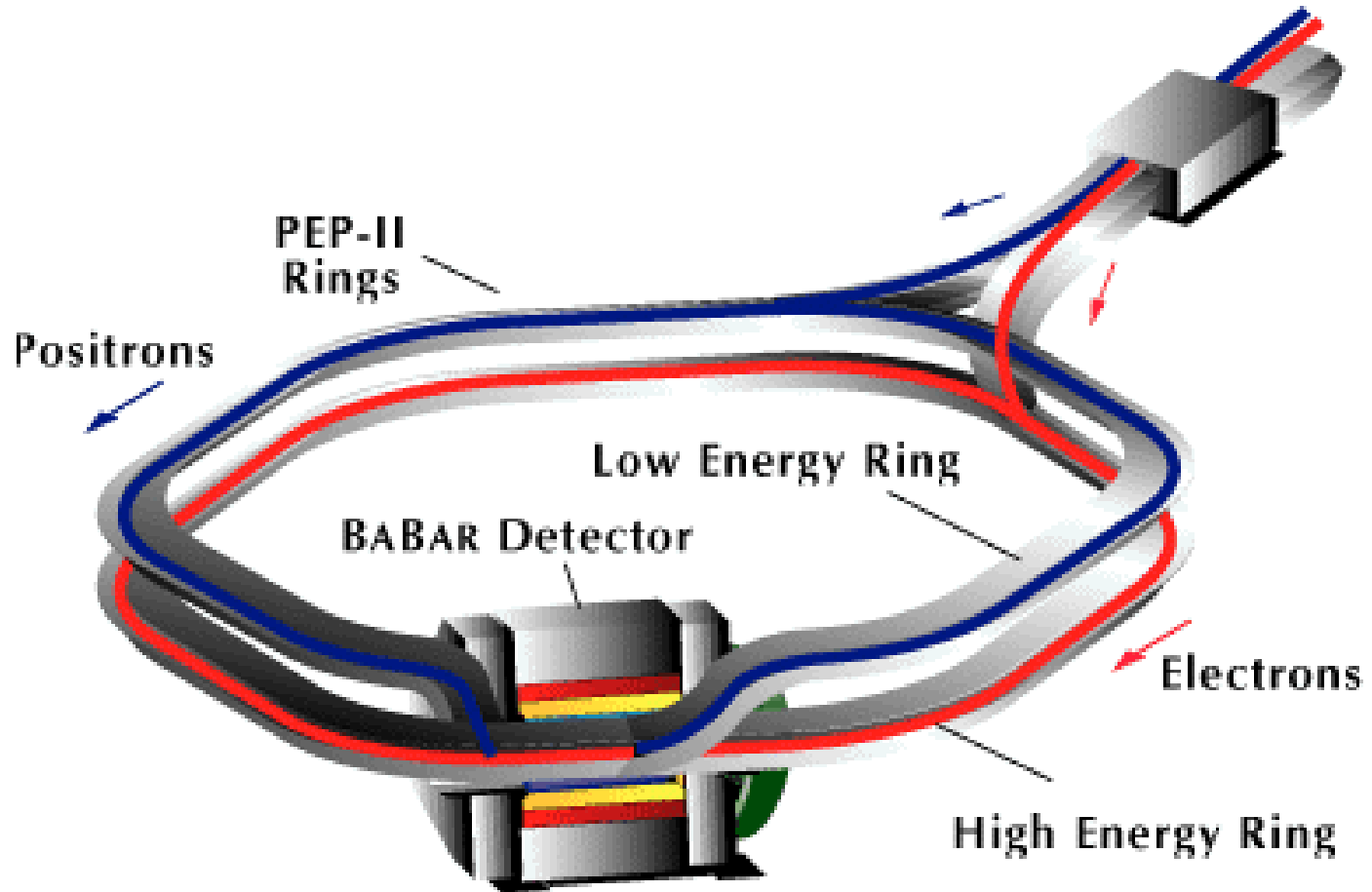

VUV Ring at NSLS



VUV ring “uncovered”

Berkeley's ALS

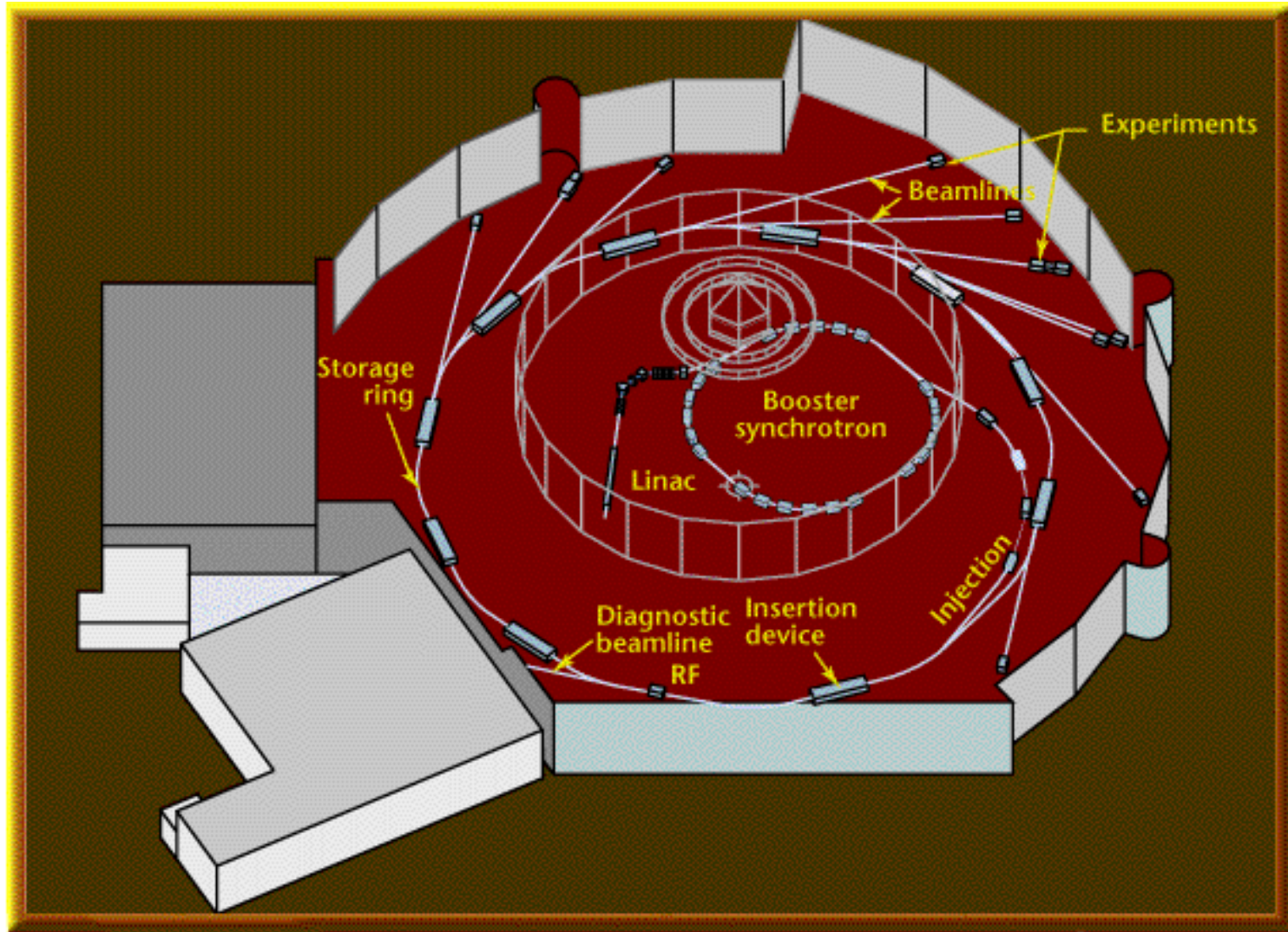

Argonne APS



ESRF

