

# Proton and Ion Linear Accelerators

## 5. Beam Focusing in Axial-Symmetric Field

---

Yuri Batygin

Los Alamos National Laboratory

U.S. Particle Accelerator School

June 7 - July 2, 2021

# Solenoid Focusing

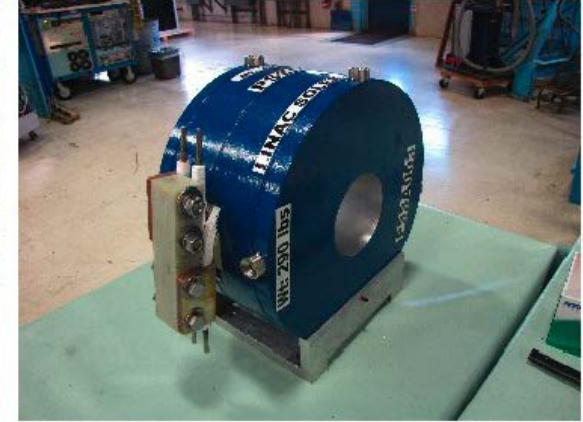
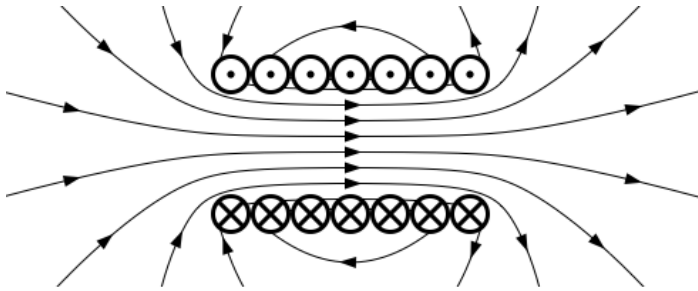

FNAL Solenoids

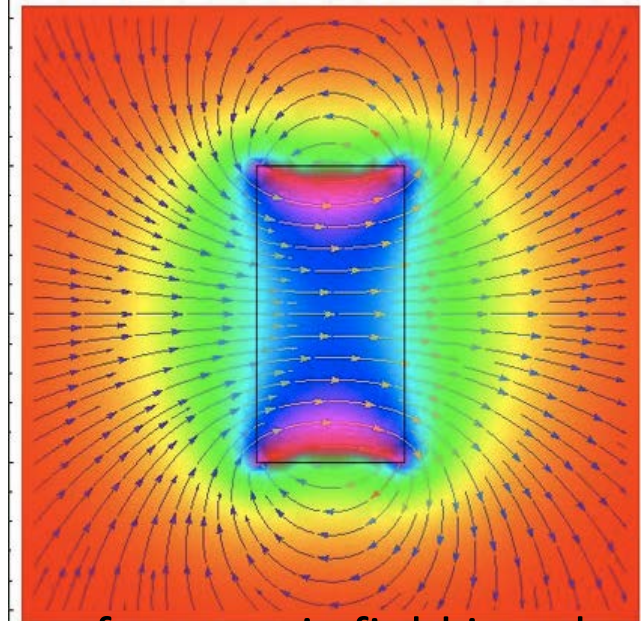
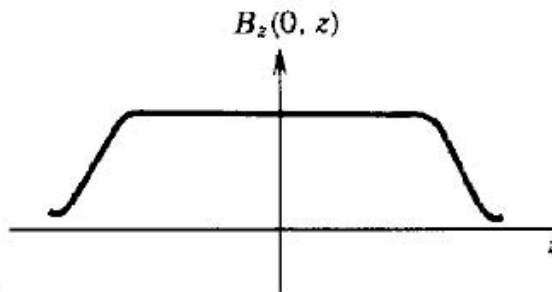
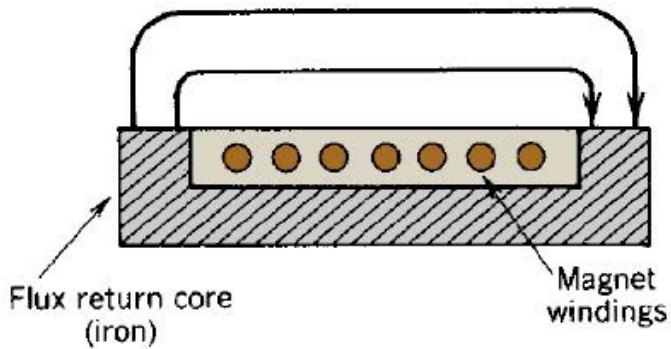
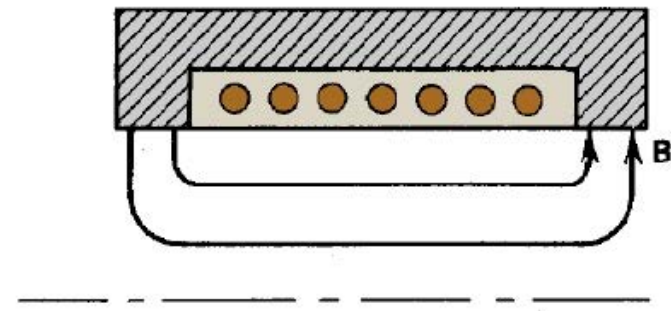

Solenoidal magnetic lens (Humphries, 1999).

Solenoidal magnetic lens (Humphries, 1999). Distribution of magnetic field in solenoid

# Hamiltonian in Cylindrical Coordinates

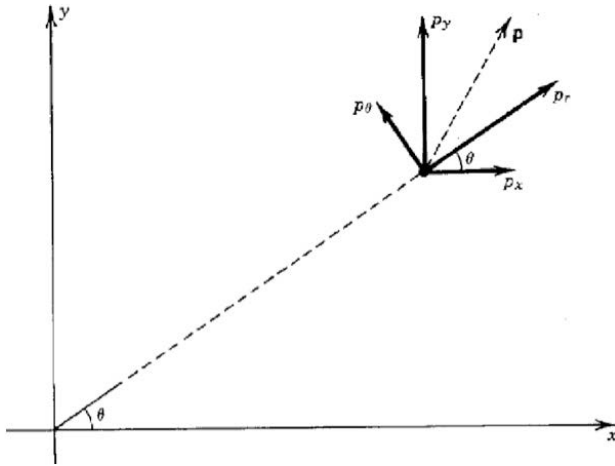

Relationship between cylindrical and Cartesian coordinates.

Hamiltonian of charged particle with charge  $q$  and mass  $m$

$$H = c \sqrt{m^2 c^2 + (P_x - qA_x)^2 + (P_y - qA_y)^2 + (P_z - qA_z)^2} + qU$$

Relationship between Cartesian and cylindrical coordinates:

$$x = r \cos \theta, \quad y = r \sin \theta, \quad z = z$$

$$P_r = P_x \cos \theta + P_y \sin \theta$$

$$P_\theta = r (-P_x \sin \theta + P_y \cos \theta)$$

$$P_z = P_z$$

Hamiltonian of particle motion in cylindrical coordinates:

$$H = c \sqrt{(mc)^2 + \left(\frac{P_\theta}{r} - qA_\theta\right)^2 + (P_r - qA_r)^2 + (P_z - qA_z)^2} + qU$$

Hamilton's equations in cylindrical coordinates read

$$\frac{dr}{dt} = \frac{\partial H}{\partial P_r}, \quad \frac{d\theta}{dt} = \frac{\partial H}{\partial P_\theta}, \quad \frac{dz}{dt} = \frac{\partial H}{\partial P_z}$$

$$\frac{dP_r}{dt} = -\frac{\partial H}{\partial r}, \quad \frac{dP_\theta}{dt} = -\frac{\partial H}{\partial \theta}, \quad \frac{dP_z}{dt} = -\frac{\partial H}{\partial z}$$

# Equation of Motion in Cylindrical Coordinates

---

Equations for particle position are

$$\frac{dr}{dt} = \frac{P_r - qA_r}{m\gamma}$$

$$\frac{d\theta}{dt} = \frac{1}{m\gamma r} (P_\theta - qA_\theta)$$

$$\frac{dz}{dt} = \frac{P_z - qA_z}{m\gamma}$$

Instead of canonical momentum, it is more common to use mechanical momentum, components:

$$p_r = m\gamma \frac{dr}{dt} = P_r - qA_r$$

$$p_\theta = m\gamma r \frac{d\theta}{dt} = \frac{P_\theta}{r} - qA_\theta$$

$$p_z = m\gamma \frac{dz}{dt} = P_z - qA_z$$

# Equation of Motions in Cylindrical Coordinates

---

Equations of motion in cylindrical coordinates are

$$\frac{dr}{dt} = \frac{p_r}{m\gamma} \quad \frac{d\theta}{dt} = \frac{p_\theta}{m\gamma r} \quad \frac{dz}{dt} = \frac{p_z}{m\gamma}$$

$$\frac{dp_r}{dt} = \frac{p_\theta^2}{m\gamma r} + q \left( E_r + \frac{p_\theta}{m\gamma} B_z - \frac{p_z}{m\gamma} B_\theta \right)$$

$$\frac{1}{r} \frac{d(rp_\theta)}{dt} = q \left( E_\theta + \frac{p_z}{m\gamma} B_r - \frac{p_r}{m\gamma} B_z \right)$$

$$\frac{dp_z}{dt} = q \left( E_z + \frac{p_r}{m\gamma} B_\theta - \frac{p_\theta}{m\gamma} B_r \right)$$

# Dynamics in Axial-Symmetric Magnetic Field

An area of special interest in beam dynamics is an axially-symmetric static field,  $E_\theta = 0$ ,  $B_\theta = 0$ , which is common in beam transport. In this case, all partial derivatives over the azimuth angle are equal to zero,  $\partial/\partial\theta = 0$ , and the canonical angular momentum is a constant of motion:

$$P_\theta = m\gamma r^2 \frac{d\theta}{dt} + r qA_\theta = \text{const} \quad (1.87)$$

Equation of radial particle motion in axial-symmetric field:

$$\ddot{r} + \frac{qE_z \beta_z}{m\gamma} \dot{r} - \frac{P_\theta^2}{m^2 \gamma^2 r^3} + r \left( \frac{qB_z}{2m\gamma} \right)^2 - \frac{qE_r}{m\gamma} = 0$$

# Magnetic Field and Vector-Potential

Vector potential of axial-symmetric magnetic field has only azimuthal component. Actually, components of magnetic field  $\partial/\partial\theta=0$  are expressed through vector potential as

$$B_z = \frac{1}{r} \frac{\partial(rA_{\theta \text{ magn}})}{\partial r}$$

$$B_r = -\frac{\partial A_{\theta \text{ magn}}}{\partial z}$$

From equation for  $B_z$  azimuthal component of vector-potential is expressed via flux of magnetic field through circular area of radius  $r$  as:

$$A_{\theta} = \frac{1}{2\pi r} \int_0^r B_z dS$$

# Dynamics in Axial-Symmetric Magnetic Field

The angular component of the vector – potential is given by

$$A_{\theta} = \frac{\Psi}{2\pi r} \quad (1.88)$$

where  $\Psi$  is the magnetic flux

$$\Psi = \int_0^r B_z 2\pi r' dr' . \quad (1.89)$$

Substitution of Eq. (1.88) into Eq. (1.87) gives:

$$r^2 \frac{d\theta}{dt} + q \frac{\Psi}{2\pi m \gamma} = \text{const} . \quad (1.90)$$



# Busch's Theorem

If we denote the initial conditions as  $\dot{\theta}_o, r_o, \Psi_o$ , Eq. (1.90) can be rewritten as

$$\boxed{r^2 \dot{\theta} - r_o^2 \dot{\theta}_o = -\frac{q}{2\pi m \gamma} (\Psi - \Psi_o)}, \quad (1.91)$$

which is known as Busch's theorem. It states that change in angular momentum of a particle in a static magnetic field is defined by the change in magnetic flux comprised by the particle trajectory.

Busch's theorem can be represented as

$$\dot{\theta} = \frac{P_\theta}{m \gamma r^2} - \omega_L, \quad (1.93)$$

where  $\omega_L$  is the Larmor frequency of particle oscillations in a longitudinal magnetic field

$$\omega_L = \frac{q B}{2m \gamma}. \quad (1.94)$$

# Particle Trajectories in Magnetic Field

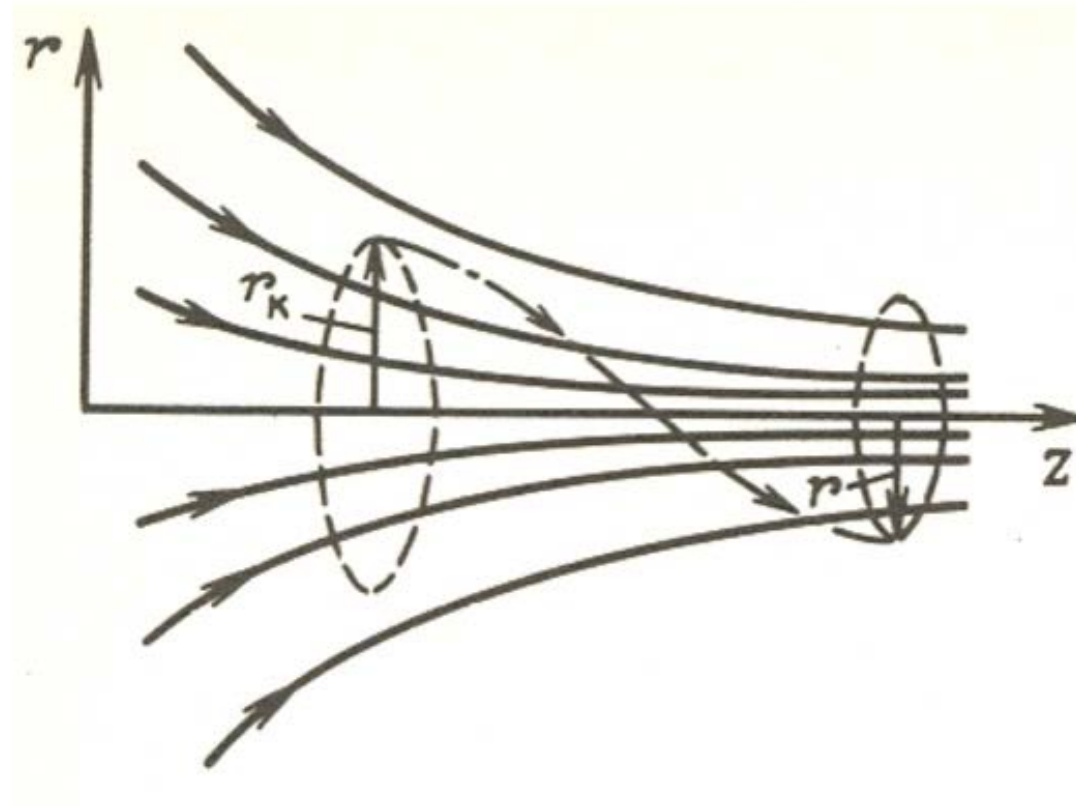

On Busch's theorem for particle in axial-symmetric magnetic field.

# Vector-Potential in Cartesian Coordinates

Consider the beam propagating in a focusing channel with longitudinal magnetic field  $B_z = B(z)$ . This field can be created by solenoids or permanent magnets. Like in quadrupole channel, we assume that all particles have the same value of longitudinal velocity  $\beta$ , which is not affected by variation of magnetic field.

Vector potential has only azimuthal field component:

$$A_{\theta \text{ magn}} = \frac{1}{2\pi r} \int_0^r B 2\pi r' dr' = \frac{B r}{2} . \quad (2.210)$$

Components of vector potential in Cartesian coordinates are:

$$A_{x \text{ magn}} = -A_{\theta \text{ magn}} \sin\theta = -B \frac{y}{2} , \quad (2.211)$$

$$A_{y \text{ magn}} = A_{\theta \text{ magn}} \cos\theta = B \frac{x}{2} . \quad (2.212)$$

# Hamiltonian in Longitudinal Magnetic Field

Hamiltonian of particle motion in presence of longitudinal magnetic field is given by

$$K = c \sqrt{m^2 c^2 + (P_x + qB \frac{y}{2})^2 + (P_y - qB \frac{x}{2})^2 + (P_z - q\beta \frac{U_b}{c})^2} + qU_b. \quad (2.213)$$

Taking into account that,  $P_z \gg q\beta U_b/c$  and repeating all derivations, resulted in Eq. (2.27), the Hamiltonian becomes

$$H = \frac{(P_x + qB \frac{y}{2})^2}{2m\gamma} + \frac{(P_y - qB \frac{x}{2})^2}{2m\gamma} + \frac{q U_b}{\gamma^2}. \quad (2.214)$$

In longitudinal magnetic field, the canonical - conjugate variables are position and canonical momentum  $(x, P_x), (y, P_y)$ , where

$$P_x = p_x - qB \frac{y}{2}, \quad (2.215)$$

$$P_y = p_y + qB \frac{x}{2}. \quad (2.216)$$

# Transformation to Larmor Frame

Emittances of the beam have to be defined at the phase planes of canonical variables  $(x, P_x)$ ,  $(y, P_y)$ , in contrast with quadrupole channel, where canonical variables are  $(x, p_x)$ ,  $(y, p_y)$ . Hamiltonian, Eq. (2.214), contains cross term  $(xP_y - yP_x)$ . Equations of motion in longitudinal magnetic field are coupled: equation in  $x$  -direction depends on  $P_y$  and that in  $y$  - direction depend on  $P_x$ . To avoid coupling, let us make a canonical transformation to new variables  $\hat{x}, \hat{P}_x, \hat{y}, \hat{P}_y$  according to generating function

$$F_2(x, \hat{P}_x, y, \hat{P}_y, t) = (x\hat{P}_x + y\hat{P}_y)\cos\theta(z) + (x\hat{P}_y - y\hat{P}_x)\sin\theta(z), \quad \theta(z) = \int_{z_0}^z \omega_L(z) dz \quad (2.217)$$

where  $\omega_L(z) = \frac{qB_z(z)}{2m\gamma}$  is the Larmor frequency. Transformation from old variables to new variables are given by

$$\hat{x} = x \cos\theta - y \sin\theta, \quad (2.218)$$

$$\hat{y} = x \sin\theta + y \cos\theta, \quad (2.219)$$

$$\hat{P}_x = P_x \cos\theta - P_y \sin\theta, \quad (2.220)$$

$$\hat{P}_y = P_y \cos\theta + P_x \sin\theta. \quad (2.221)$$

# KV Envelope Equation in Larmor Frame

New Hamiltonian,  $\widehat{H} = H + \frac{\partial F_2}{\partial t}$ , is given by

$$\widehat{H} = \frac{\widehat{P}_x^2 + \widehat{P}_y^2}{2m\gamma} + m\gamma\omega_L^2 \frac{(\widehat{x}^2 + \widehat{y}^2)}{2} + q \frac{U_b}{\gamma^2}. \quad (2.222)$$

Hamiltonian, Eq. (2.222), is similar to that for quadrupole channel, Eq. (2.96). Analysis resulted in KV envelope equations, can be applied here as well. Because of the axial symmetry of the beam propagating in magnetic field, there will be only one envelope equation instead of two in quadrupole channel. Repeating the same derivations, which resulted in Eqs. (2.146), (2.147), we can obtain KV envelope equation for round beam in Larmor frame:

$$\widehat{R}'' - \frac{\widehat{\mathcal{E}}}{\widehat{R}^3} + k(z)\widehat{R} - \frac{2I}{I_c \beta^3 \gamma^3 \widehat{R}} = 0, \quad (2.223)$$

where

$$k(z) = \left( \frac{qB(z)}{2mc\beta\gamma} \right)^2 \quad (2.224)$$

# 4D Ellipsoid in Larmor Frame

In KV distribution, particles occupy surface of four-dimensional ellipsoid:

$$F(\hat{x}, \hat{x}', \hat{y}, \hat{y}') = \gamma_o \hat{x}^2 + 2\alpha_o \hat{x} \hat{x}' + \beta_o \hat{x}'^2 + \gamma_o \hat{y}^2 + 2\alpha_o \hat{y} \hat{y}' + \beta_o \hat{y}'^2 - F_o = 0. \quad (2.225)$$

Here parameters  $\beta_o$  and  $\gamma_o$  are ellipse parameters, not the particle velocity and energy. Projections of the distribution at every phase plane are uniformly populated ellipses:

$$\gamma_o \hat{x}^2 + 2\alpha_o \hat{x} \hat{x}' + \beta_o \hat{x}'^2 = \hat{\epsilon} \quad (2.226)$$

$$\gamma_o \hat{y}^2 + 2\alpha_o \hat{y} \hat{y}' + \beta_o \hat{y}'^2 = \hat{\epsilon} \quad (2.227)$$

where

$$\hat{x}' = \frac{\hat{P}_x}{m\gamma\beta_z c} \quad (2.228)$$

$$\hat{y}' = \frac{\hat{P}_y}{m\gamma\beta_z c} \quad (2.229)$$

# 4D Ellipsoid in Laboratory Frame

Substitution of Eqs. (2.218) - (2.221) into Eq. (2.225) gives for the boundary of the four-dimensional ellipsoid occupied by the beam in laboratory frame:

$$F(x, x', y, y') = \gamma_o x^2 + 2\alpha_o x x' + \beta_o x'^2 + \gamma_o y^2 + 2\alpha_o y y' + \beta_o y'^2 - F_o = 0. \quad (2.230)$$

Boundaries of projections of the four-dimensional beam ellipsoid and of their projections at phase planes are the same both in laboratory frame, and in Larmor frame. From Eqs. (2.218) - (2.221), transformation of phase space elements and area element in real space are

$$d\hat{x} d\hat{P}_x = dx dP_x, \quad (2.231)$$

$$d\hat{y} d\hat{P}_y = dy dP_y, \quad (2.232)$$

$$d\hat{x} d\hat{y} = dx dy. \quad (2.233)$$



# KV Envelope Equation in Laboratory Frame

Therefore, distribution of particles within projections in both frames are also the same, and uniformly populated ellipses in Larmor frame remain the uniformly populated in laboratory frame. Finally, beam emittance and beam radius are the same in both frames,  $\hat{\epsilon} = \hat{\epsilon}$ ,  $R = \hat{R}$ . Therefore, we can write KV envelope equation in the laboratory frame as well:

$$\frac{d^2 R}{dz^2} + \frac{\omega_L^2(z)}{(\beta c)^2} R - \frac{\epsilon^2}{R^3} - \frac{2I}{I_c R (\beta \gamma)^3} = 0$$

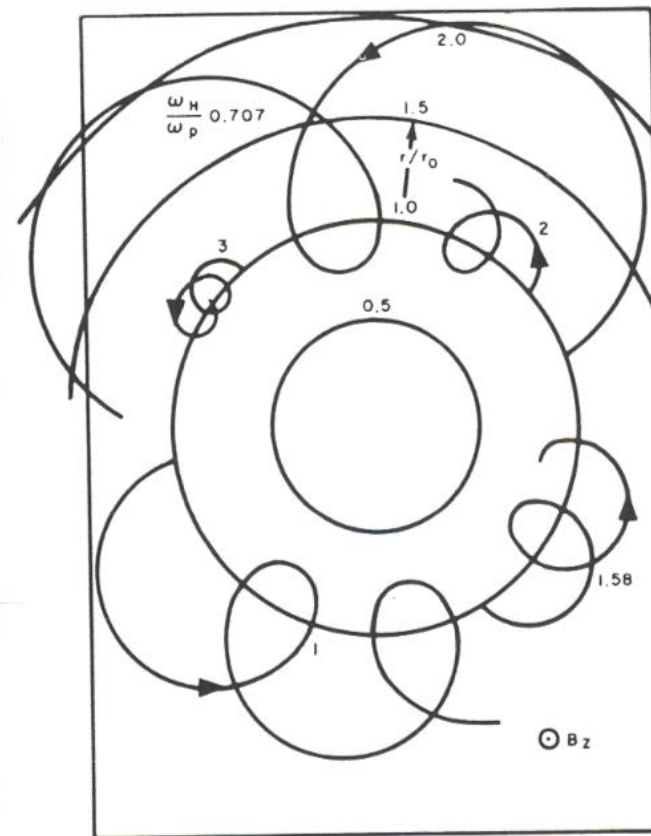

Typical particle trajectories in magnetic field with beam space charge (from G. Brewer, 1967).

# Beam Equilibrium in Magnetic Field

Important case is the beam transport in a constant magnetic field  $B(z) = B$ , which is a uniform focusing structure. Matched beam corresponds to transport with constant envelope,  $R'' = 0$ :

$$-\frac{\varepsilon^2}{R_e^3} + \left(\frac{qB}{2mc\beta\gamma}\right)^2 R_e - \frac{2I}{I_c\beta^3\gamma^3 R_e} = 0 \quad (2.235)$$

where  $R_e$  is the equilibrium beam radius. Acceptance of the channel,  $A$ , and normalized acceptance,  $\varepsilon_{ch}$ , are obtained from Eq. (2.235) taking the value of beam current  $I = 0$ , and equilibrium beam radius equal to aperture of the channel,  $R_e = a$ :

$$A = \omega_L \frac{a^2}{\beta c}, \quad \varepsilon_{ch} = \frac{qB a^2}{2mc} \quad (2.236)$$

Let us note, that normalize acceptance of the channel with constant longitudinal magnetic field is energy - independent. In the equilibrium, beam envelope does not perform any oscillations and beam occupies the smallest possible area. From Eq. (2.235), the required magnetic field to keep in equilibrium the beam with radius  $R_e$ , emittance  $\varepsilon$ , and current  $I$ , is

$$B = \frac{2mc\beta\gamma}{qR_e} \sqrt{\left(\frac{\varepsilon}{R_e}\right)^2 + \frac{2I}{I_c\beta^3\gamma^3}} \quad (2.237)$$

# Maximum Transported Beam Current in Uniform Magnetic Field

Taking  $R_e = a$ , and expressing explicitly the value of beam current from the last equation gives for maximum transported beam current:

$$I_{max} = \frac{I_c}{2} (\beta\gamma) \left( \frac{qBa}{2mc} \right)^2 \left( 1 - \frac{\varepsilon^2}{A^2} \right). \quad (2.239)$$

Equation (2.239) can be re-written as

$$I_{max} = \frac{I_c}{2} (\beta\gamma) \left( \frac{\varepsilon_{ch}}{a} \right)^2 \left( 1 - \frac{\varepsilon^2}{\varepsilon_{ch}^2} \right). \quad (2.240)$$

$I = 0, \varepsilon = A$

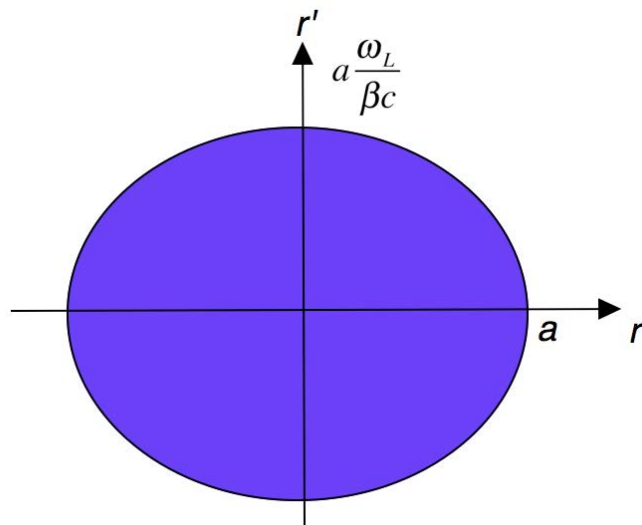

$I \neq 0, \varepsilon < A$

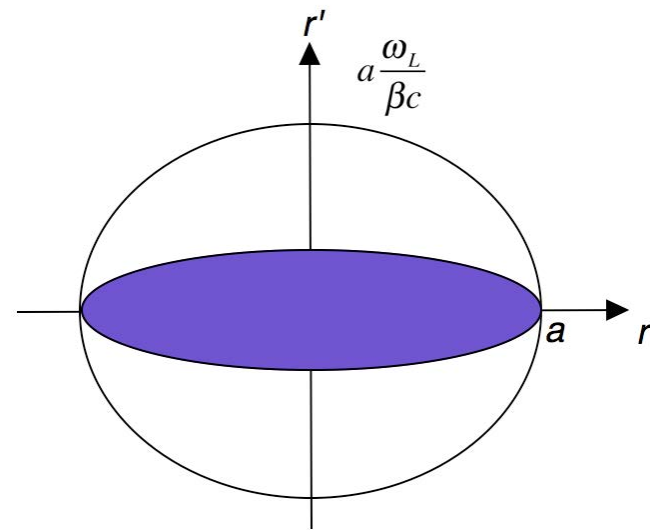

Matched beam in uniform magnetic field for zero current mode, and for space charge dominated mode.

# Brillouin Flow

Important specific case is the equilibrium of the beam with negligible emittance  $\varepsilon = 0$ , which is called the Brillouin flow:

$$BR_e = 2\sqrt{2} \frac{mc}{q} \sqrt{\frac{I}{\beta\gamma I_c}} . \quad (2.241)$$

As far as beam with zero emittance cannot be achieved when particle source is inserted in magnetic field, Brillouin flow is realized for the beam born outside magnetic field. If particles are born with zero beam emittance, the transverse mechanical momentum of all particles at the source are equal to zero. Due to conservation of azimuthal canonical particle momentum, all particles obtain azimuthal rotation after entering magnetic field

$$p_\theta = -q \frac{B_z r}{2} , \quad \text{or} \quad \dot{\theta} = -\omega_L . \quad (2.242)$$

# Oscillations Around Equilibrium Radius

Realistic beams usually are not in equilibrium with focusing magnetic field. Consider small deviation of beam radius from equilibrium condition,  $R = R_e + x$ , where  $x \ll R_e$ . In this case

$$\frac{1}{R} \approx \frac{1}{R_e} \left(1 - \frac{\xi}{R_e}\right), \quad \frac{1}{R^3} \approx \frac{1}{R_e^3} \left(1 - 3 \frac{\xi}{R_e}\right) \quad (2.243)$$

Then, envelope equation becomes

$$\frac{d^2 \xi}{dz^2} - \frac{\vartheta^2}{R_e^3} \left(1 - 3 \frac{\xi}{R_e}\right) + \frac{(\omega_L)^2}{\beta c} (R_e + \xi) - \frac{2 I}{I_c \beta^3 \gamma^3 R_e} \left(1 - \frac{\xi}{R_e}\right) = 0. \quad (2.245)$$

Taking into account equilibrium condition, Eq (2.235), the equation for small deviation of the beam from equilibrium is

$$\frac{d^2 \xi}{dz^2} + 3 \frac{\vartheta^2}{R_e^4} \xi + \frac{(\omega_L)^2}{\beta c} \xi + \frac{2 I}{I_c \beta^3 \gamma^3 R_e^2} \xi = 0. \quad (2.246)$$

Beam equilibrium condition, Eq. (2.235), can be written as

$$\frac{\vartheta^2}{R_e^4} = \frac{(\omega_L)^2}{\beta c} \frac{1}{1 + b}. \quad (2.247)$$

where  $b$  is the dimensionless beam brightness:

$$b = \frac{2}{(\beta \gamma)^3} \frac{I R_e^2}{I_c \vartheta^2}. \quad (2.248)$$

# Oscillations Around Equilibrium Radius (cont.)

Last term in Eq. (2.246) can be also expressed through parameter  $b$ :

$$\frac{2I}{I_c \beta^3 \gamma^3 R_e^2} \xi = \frac{\varkappa^2}{R_e^4} b \xi. \quad (2.249)$$

Substitution of Eqs. (2.247), (2.249) into Eq. (2.246) gives for small derivation:

$$\frac{d^2 \xi}{dz^2} + 2 \left( \frac{\omega_L}{\beta c} \right)^2 \frac{(2+b)}{1+b} \xi = 0. \quad (2.250)$$

Solution of Eq. (2.250) can be written as

$$\xi = \xi_o \cos \left( \sqrt{2 \frac{(2+b)}{1+b}} \frac{\omega_L}{\beta c} z + \Psi_o \right). \quad (2.251)$$

From Eq. (2.251) it follows that in emittance-dominated regime,  $b \rightarrow 0$ , envelope oscillates with double Larmor frequency:

$$\xi = \xi_o \cos \left( 2 \frac{\omega_L}{\beta c} z + \Psi_o \right), \quad (2.252)$$

while in space-charge dominated regime,  $b \rightarrow \infty$ , frequency of oscillation is  $\sqrt{2}$  smaller:

$$\xi = \xi_o \cos \left( \sqrt{2} \frac{\omega_L}{\beta c} z + \Psi_o \right). \quad (2.253)$$

# Required Transverse Focusing in Presence of RF field

Hamiltonian of particle motion in RF field with solenoid focusing

$$H = \frac{\hat{P}_x^2 + \hat{P}_y^2}{2m\gamma} + m\gamma \frac{r^2}{2} \left( \omega_L^2 - \frac{\Omega^2}{2} \frac{\sin\phi}{\sin\phi_s} \right) + q \frac{U_b}{\gamma^2}$$

Transverse oscillation frequency in presence of RF field

$$\Omega_r^2 = \omega_L^2 - \frac{\Omega^2}{2} \frac{\sin\phi}{\sin\phi_s}$$

Envelope equation

$$\frac{d^2 R}{dz^2} - \frac{\vartheta^2}{R^3} + \frac{\Omega_r^2}{(\beta c)^2} R - \frac{2I}{I_c (\beta\gamma)^3 R} = 0$$

Beam equilibrium condition

$$\frac{d^2 R_e}{dz^2} = 0$$

$$\frac{\Omega_r^2}{(\beta c)^2} R_e + \frac{\vartheta^2}{R_e^3} - \frac{2I}{I_c (\beta\gamma)^3 R_e} = 0$$

$$\Omega_r^2 = \left( \frac{\beta c}{R_e} \right)^2 \left( \frac{\vartheta^2}{R_e^2} + \frac{2I}{I_c (\beta\gamma)^3} \right)$$

Required magnetic field

$$B = \frac{2mc\beta\gamma}{qR_e} \sqrt{\left( \frac{\vartheta}{R_e} \right)^2 + \frac{2I}{I_c (\beta\gamma)^3} + \pi \left( \frac{qE\lambda}{mc^2} \right) \frac{\sin\phi}{(\beta\gamma)^3} \left( \frac{R_e}{\lambda} \right)^2}$$

## Beam Transport in Periodic Structure of Axial-Symmetric Lenses

Periodic axial-symmetric magnetic field is often used in focusing of particle beams. Most existing ion Low Energy Beam Transport lines are based on solenoid focusing. Modern accelerator projects utilize superconducting solenoids in combination with superconducting accelerating cavities for acceleration of high-intensity particle beams.

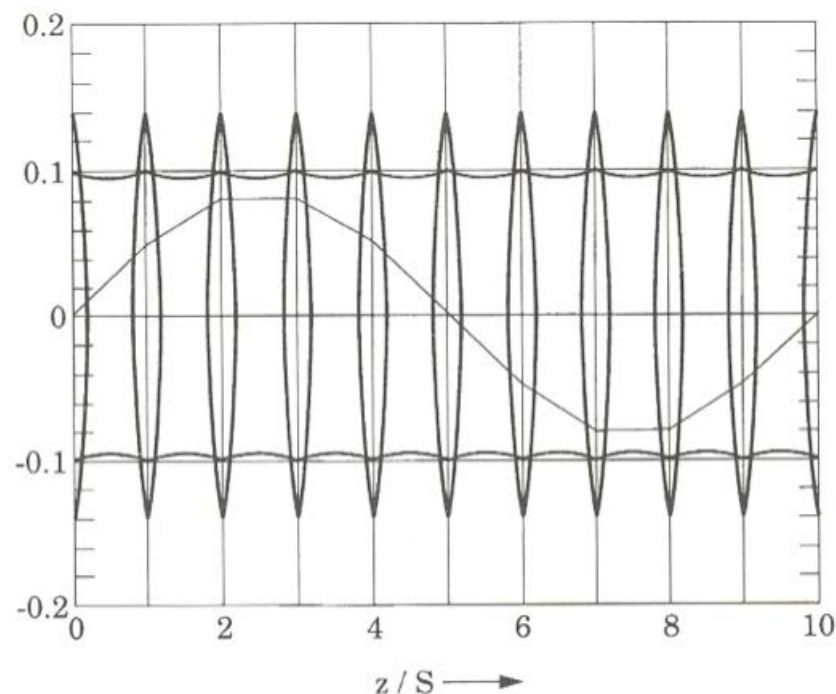

Particle trajectory and matched beam envelope in a periodic thin lens array (Reiser, 1994).



# Coupled Equations of Motion

Equations of motion of a single particle in Cartesian coordinates

$$\frac{dp_x}{dt} = q \left( \frac{p_y}{m\gamma} B_z - \frac{p_z}{m\gamma} B_y \right)$$

$$\frac{dp_y}{dt} = q \left( -\frac{p_x}{m\gamma} B_z + \frac{p_z}{m\gamma} B_x \right)$$

From  $\text{div}\vec{B} = 0$  connection between radial and longitudinal magnetic field components:

$$B_r = -\frac{r}{2} \frac{dB_z}{dz}$$

Component of magnetic field in Cartesian coordinates:

$$B_x = -\frac{x}{2} \frac{dB_z}{dz} \quad B_y = -\frac{y}{2} \frac{dB_z}{dz}$$

Equations of motion in Cartesian coordinates:

$$x'' - 2Ky' - yK' = 0$$

$$y'' + 2Kx' + xK' = 0$$

Where  $K(z)$  is the rigidity of solenoid:

$$K(z) = \frac{qB_z(z)}{2mc\beta\gamma} = \frac{\omega_L(z)}{c\beta}$$

# Linear Transfer Matrix of Solenoid

Transverse particle motion in magnetic field is coupled between  $x$  - and  $y$  - directions. Introducing new variable

$$w = x + iy$$

the system of two equations of motion can be written as

$$w'' + 2iKw' + iK'w = 0$$

Introduce new variable (change to rotation system of coordinates)

$$\bar{w} = we^{-i\theta(z)}$$

New equation of motion in rotation system

$$\bar{w}'' + K^2\bar{w} = 0$$

Transfer matrix in rotation system of coordinates

$$\begin{pmatrix} \hat{x} \\ \hat{x}' \\ \hat{y} \\ \hat{y}' \end{pmatrix} = \begin{pmatrix} \cos\theta & \sin\theta / K & 0 & 0 \\ -\sin\theta K & \cos\theta & 0 & 0 \\ 0 & 0 & \cos\theta & \sin\theta / K \\ 0 & 0 & -\sin\theta K & \cos\theta \end{pmatrix} \begin{pmatrix} \hat{x}_o \\ \hat{x}'_o \\ \hat{y}_o \\ \hat{y}'_o \end{pmatrix}$$

where angle  $\theta = KD$

# Matrix Method for Periodic Structure of Axial-Symmetric Lenses

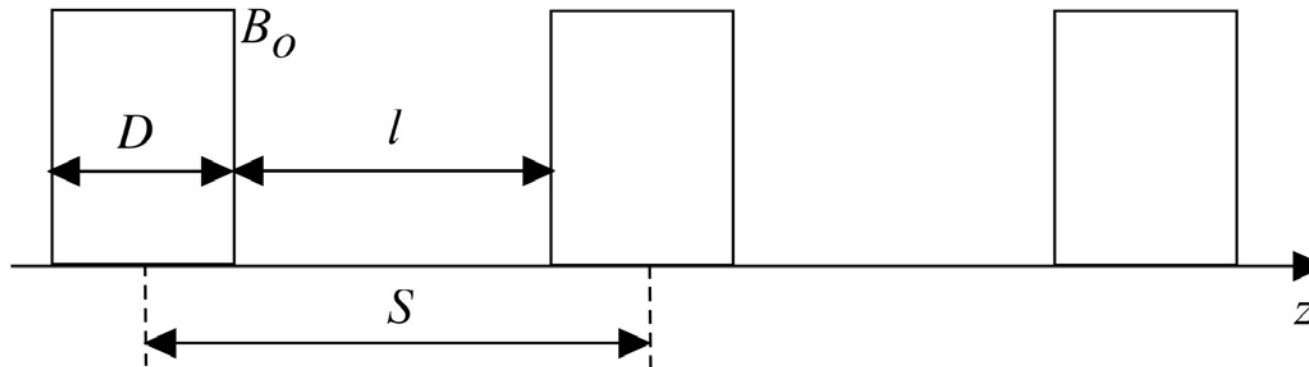

Periodic structure of focusing solenoids.

The transformation matrix in a rotating frame through a period of the structure between centers of solenoids

$$\begin{pmatrix} \cos \frac{\theta}{2} & \frac{D}{\theta} \sin \frac{\theta}{2} \\ -\frac{\theta}{D} \sin \frac{\theta}{2} & \cos \frac{\theta}{2} \end{pmatrix} \begin{pmatrix} 1 & l \\ 0 & 1 \end{pmatrix} \begin{pmatrix} \cos \frac{\theta}{2} & \frac{D}{\theta} \sin \frac{\theta}{2} \\ -\frac{\theta}{D} \sin \frac{\theta}{2} & \cos \frac{\theta}{2} \end{pmatrix} = \begin{pmatrix} \cos \theta - \frac{l}{2D} \theta \sin \theta & \frac{D}{\theta} \sin \theta + l \cos^2 \frac{\theta}{2} \\ -\frac{\theta}{D} \sin \theta + l \left(\frac{\theta}{D}\right)^2 \sin^2 \frac{\theta}{2} & \cos \theta - \frac{l}{2D} \theta \sin \theta \end{pmatrix}$$

Rotational angle of particle trajectory in a solenoid

$$\theta = \frac{qB_0 D}{2mc\beta\gamma}$$

# Phase Advance and Beta-Function

From the matrices, the value of betatron tune shift per period,  $\mu_o$ , is determined by

$\cos \mu_o = \cos \theta - \theta \sin \theta \frac{(S-D)}{2D}$ . Adopting the expansions  $\cos \xi = 1 - \xi^2 / 2 + \xi^4 / 24$  and  $\sin \xi = \xi - \xi^3 / 6$ , the value of betatron tune shift per period reads:

$$\mu_o = \theta \sqrt{\frac{S}{D}} \sqrt{1 - \frac{\theta^2}{6} \left[1 - \frac{1}{2} \left(\frac{D}{S} + \frac{S}{D}\right)\right]}. \quad (1.4)$$

Thus, the maximum and minimum values of the beta-function  $\beta_{\max/\min} = m_{12} / \sin \mu_o$  in the channel are given by:

$$\beta_{\min} = \frac{(S-D)\cos\theta - \frac{(S-D)^2\theta}{4D}\sin\theta + D\frac{\sin\theta}{\theta}}{\sin\mu_o}$$

$$\beta_{\max} = \frac{S\cos^2\frac{\theta}{2}\left[1 - \frac{D}{S}\left(1 - \frac{\tan\theta/2}{(\theta/2)}\right)\right]}{\sin\mu_o}$$

More info: Y.B., Nuclear  
Instruments and  
Methods in Physics  
Research A 772 (2015)  
93–102

# Periodic Envelopes and Acceptance of the Channel

Equations for beta-functions determine the maximum  $R_{\max} = \sqrt{\beta_{\max} \vartheta}$  and minimum  $R_{\min} = \sqrt{\beta_{\min} \vartheta}$  matched envelope of the beam with unnormalized emittance,  $\vartheta$ , and negligible beam current,  $I = 0$ . Acceptance of the channel with aperture radius,  $a$ , is given by  $A = a^2 / \beta_{\max}$ :

$$A = \frac{a^2 \sin \mu_o}{S \cos^2 \frac{\theta}{2} \left[ 1 - \frac{D}{S} \left( 1 - \frac{\tan \theta / 2}{(\theta / 2)} \right) \right]}$$

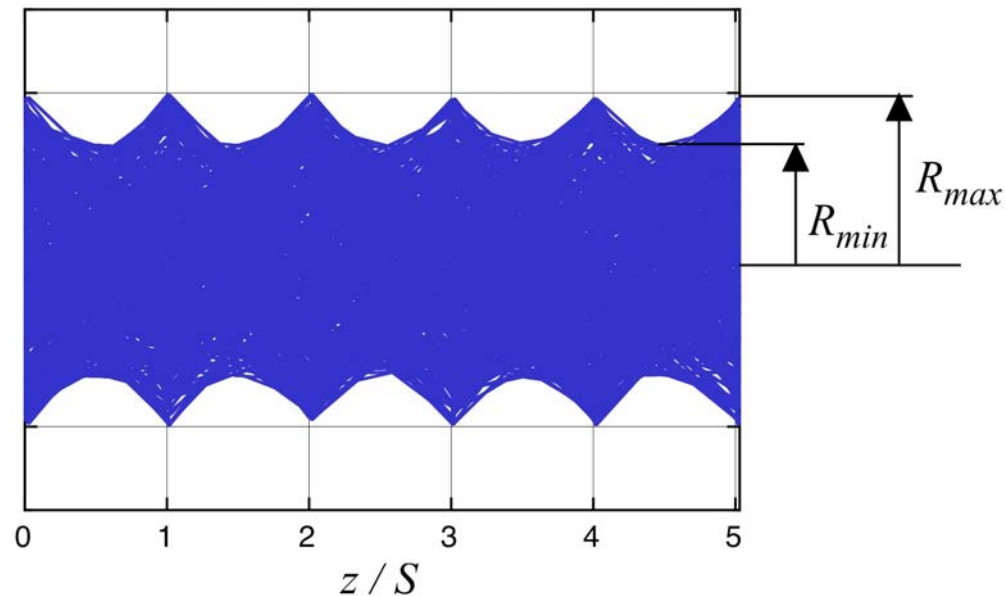

# Focal Length of a Thin Solenoid

Assume that canonical momentum of particle before entering the lens is  $P_\theta = 0$ , which corresponds to incident particle without initial rotation. Paraxial particle equation of particle motion is then given by

$$\ddot{r} + r \left( \frac{qB_z}{2m\gamma} \right)^2 = 0. \quad (2.254)$$

If the length of the lens is short with respect to focal length, particle position might be considered unchanged within the lens, while slope of particle trajectory is changed. Integration of Eq. (2.254) gives for slope of particle trajectory

$$r' = r'_o - \frac{r_o}{f}$$

where focal length  $f$  of short magnetic lens is achieved by integration of Eq. (2.254):

$$\frac{1}{f} = \left( \frac{q}{2mc\beta\gamma} \right)^2 \int_{-\infty}^{\infty} B_z^2(z) dz. \quad (2.255)$$

With approximation of the field distribution in magnetic lens by “step” function with constant value of magnetic field  $B_o$  within the lens of length  $D$ , the focal length is

$$f = \frac{4}{D} \left( \frac{mc\beta\gamma}{qB_o} \right)^2$$

# Thin Lens Analysis of Periodic Focusing Circle Lenses

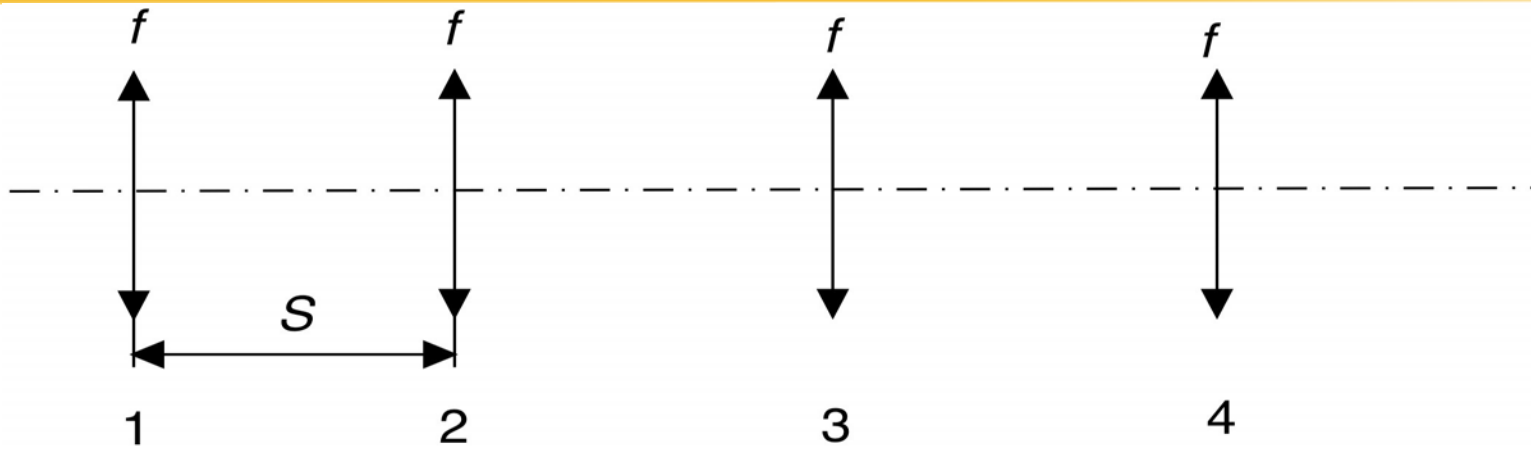

Focal length of thin solenoid lens

$$f = \frac{D}{\theta^2} = \frac{4}{D} \left( \frac{mc\beta\gamma}{qB_o} \right)^2$$

Transformation matrix between lens centers:

$$M_2 M_S M_1 = \begin{pmatrix} 1 & 0 \\ -\frac{1}{2f} & 1 \end{pmatrix} \begin{pmatrix} 1 & S \\ 0 & 1 \end{pmatrix} \begin{pmatrix} 1 & 0 \\ -\frac{1}{2f} & 1 \end{pmatrix} = \begin{pmatrix} 1 - \frac{S}{2f} & S \\ -\frac{1}{f} + \frac{S}{4f^2} & 1 - \frac{S}{2f} \end{pmatrix}$$

Phase advance per period

$$\cos \mu_o \approx 1 - \frac{\mu_o^2}{2} = \frac{m_{11} + m_{22}}{2} = 1 - \frac{S}{2f}$$

$$\mu_o = \sqrt{\frac{S}{f}}$$

# Thin Lens Analysis of Periodic Focusing Circle Lenses

Max value of beta-function

$$\beta_{\max} = \frac{m_{12}}{\sin \mu_o}$$

$$\beta_{\max} = \frac{S}{\sin \mu_o}$$

Transformation matrix  
between drift centers

$$M_{\frac{S}{2}} M_f M_{\frac{S}{2}} = \begin{pmatrix} 1 & \frac{S}{2} \\ 0 & 1 \end{pmatrix} \begin{pmatrix} 1 & 0 \\ -\frac{1}{f} & 1 \end{pmatrix} \begin{pmatrix} 1 & \frac{S}{2} \\ 0 & 1 \end{pmatrix} = \begin{pmatrix} 1 - \frac{S}{2f} & \frac{S}{2} \left(2 - \frac{S}{2f}\right) \\ -\frac{1}{f} & 1 - \frac{S}{2f} \end{pmatrix}$$

Min value of beta-function

$$\beta_{\min} = \frac{m_{12}}{\sin \mu_o}$$

$$\beta_{\min} = \frac{S}{\sin \mu_o} \left(1 - \frac{S}{4f}\right)$$

$$\beta_{\min} = \frac{S}{\sin \mu_o} \left(1 - \frac{\mu_o^2}{4}\right)$$



# Acceptance and Stability Criteria

Acceptance of the channel

$$A = \frac{a^2}{\beta_{\max}}$$

$$A = \frac{a^2}{S} \sin \mu_o$$

Maximum acceptance

$$A_{\max} = \frac{a^2}{S}$$

$$\mu_o = \frac{\pi}{2} \quad \cos \mu_o = 0 \quad S = 2f$$

Single particle stability criteria:

$$|\cos \mu_o| \leq 1 \quad 0 \leq S \leq 4f$$

$$\frac{f}{S} \geq \frac{1}{4}$$

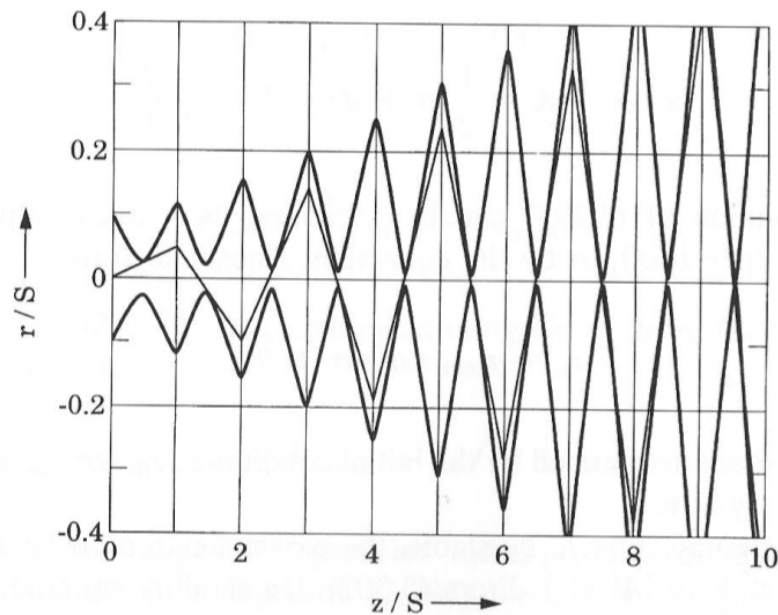

**Figure 3.25.** Particle trajectory and beam envelope in a periodic thin-lens array with focal length  $f = 0.246S$ , slightly below the stability threshold ( $f = 0.25S$ ). The particle motion is unstable in this case.

# Matching of the Beam with Negligible Current

Max beam radius  $R_{\max} = \sqrt{\beta_{\max} \varepsilon}$   $R_{\max} = \sqrt{\frac{\varepsilon S}{\sin \mu_o}}$

$$R_{\max} = \sqrt{\varepsilon S} \left[ \frac{4\left(\frac{f}{S}\right)^2}{4\left(\frac{f}{S}\right) - 1} \right]^{1/4}$$

Min beam radius  $R_{\min} = \sqrt{\beta_{\min} \varepsilon}$

$$R_{\min} = R_{\max} \sqrt{1 - \frac{S}{4f}}$$

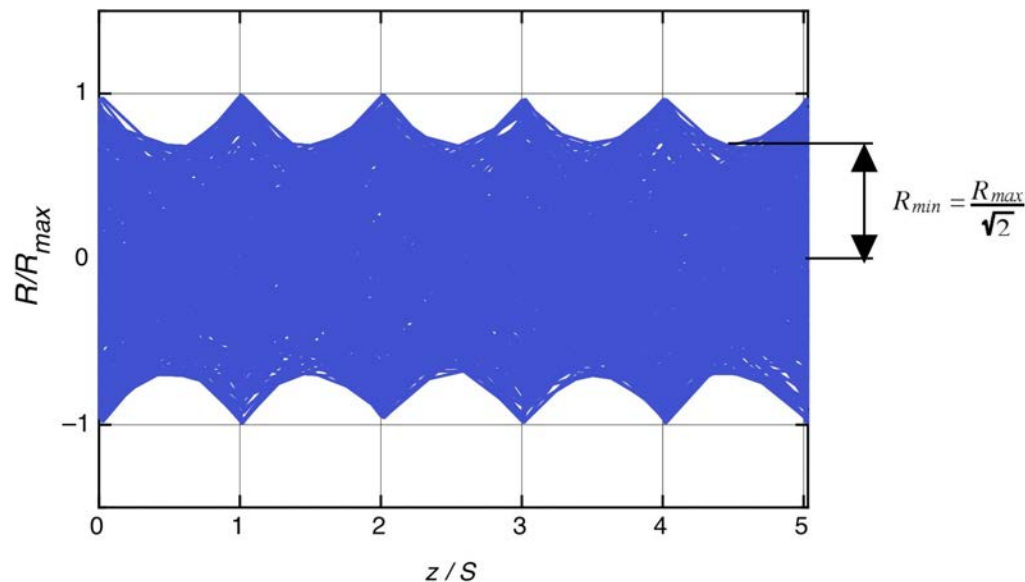

For max acceptance  $S = 2f$

$$\frac{R_{\max}}{R_{\min}} = \sqrt{2}$$

Matched beam with zero current in periodic structure of axial-symmetric lenses.

# Dynamics of Space-Charge Dominated Beam in Periodic Solenoid Structure

Envelope Equation

$$\frac{d^2 R}{dt^2} + \omega_L^2 R - \frac{\varepsilon^2 (\beta c)^2}{R^3} - \frac{2I c^2}{I_c R \beta \gamma^3} = 0$$

Fourier Expansion of Magnetic Field  $B^2(z) = B_o^2 \left[ \frac{D}{S} + \frac{2}{\pi} \sum_{n=1}^{\infty} \frac{1}{n} \sin\left(\frac{\pi n D}{S}\right) \cos\left(\frac{2\pi n z}{S}\right) \right]$

Envelope Equation with Expansion of Magnetic Field

$$\frac{d^2 R}{dt^2} = -\frac{R}{2\pi} \left(\frac{qB_o}{m\gamma}\right)^2 \sum_{n=1}^{\infty} \frac{1}{n} \sin\left(\frac{\pi n D}{S}\right) \cos\left(\frac{2\pi n \beta c t}{S}\right) - \frac{RD}{4S} \left(\frac{qB_o}{m\gamma}\right)^2 + \frac{(\varepsilon \beta c)^2}{R^3} + \frac{2Ic^2}{I_c R \beta \gamma^3}$$

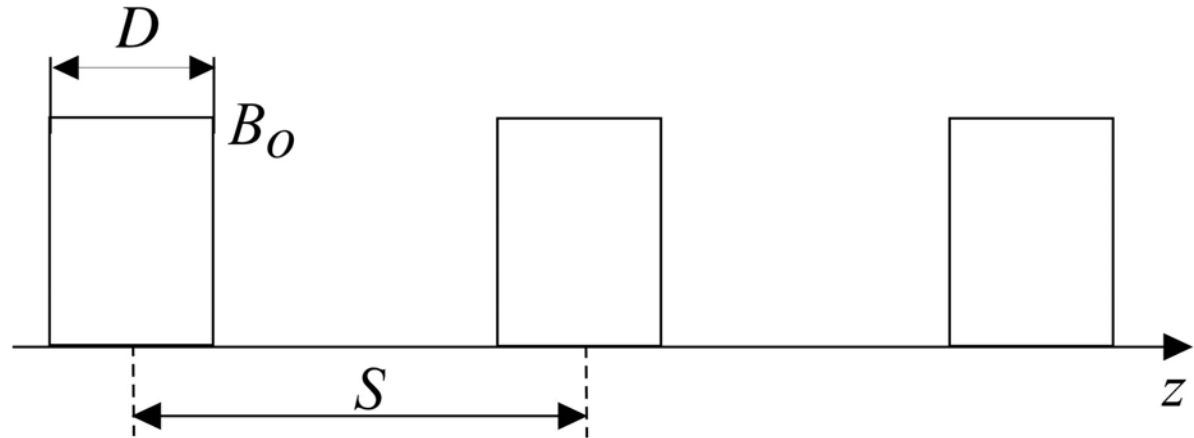

# Averaged Beam Envelope

According to the averaging method, such motion can be approximated by combination of slow variable  $R_{aver}(t)$  and small amplitude fast oscillations  $\xi(t)$ :

$$R(t) = R_{aver}(t) + \xi(t) \quad (3.7)$$

Averaging method gives the same value for betatron tune shift as matrix method. Equation for slow envelope variable

$$\frac{d^2 R_{aver}}{dz^2} - \frac{\varepsilon^2}{R_{aver}^3} + \frac{\mu_o^2}{S^2} R_{aver} - \frac{P^2}{R_{aver}} = 0 \quad (3.18)$$

Fast oscillation component of the beam envelope is determined by

$$\xi(z) \approx -\frac{q}{m\gamma} \frac{F_1(R_{aver})}{\omega_1^2} \cos \omega_1 t = R_{aver} \frac{\theta^2}{2\pi^3} \left(\frac{S}{D}\right)^2 \sin\left(\pi \frac{D}{S}\right) \cos\left(2\pi \frac{z}{S}\right) \quad (3.20)$$

# Matched Beam in Periodic Channel

Finally, solution of envelope equation can be expressed as

$$\boxed{R(z) = R_{aver}(z) \left(1 + v_{\max} \cos 2\pi \frac{z}{S}\right)}, \quad \boxed{v_{\max} = \frac{\theta^2}{2\pi^3} \left(\frac{S}{D}\right)^2 \sin\left(\pi \frac{D}{S}\right)} \quad (3.21)$$

Matched beam corresponds to constant value of average beam envelope

$R_{aver}(z) = \bar{R}_{aver}$  and can be determined from envelope equation assuming  $R_{aver}''(z) = 0$ :

$$\bar{R}_{aver} = \bar{R}_{aver}(0) \sqrt{b_o + \sqrt{1 + b_o^2}} \quad (3.22)$$

where  $\bar{R}_{aver}(0)$  is the matched average beam size with negligible space charge,

$$\bar{R}_{aver}(0) = \sqrt{\frac{\varepsilon S}{\mu_o}} \quad (3.23)$$

and  $b_o$  is the space charge parameter:  $b_o = \frac{1}{(\beta\gamma)^3} \frac{I}{I_c} \left(\frac{\bar{R}_{aver}(0)}{\varepsilon}\right)^2$

# Maximum Beam Current

The minimum and maximum matched beam envelope in presence of space charge forces are given by:

$$R_{\max/\min} = \bar{R}_{aver} (1 \pm \nu_{\max}), \quad (3.25)$$

Maximum beam current is achieved when maximum beam size is equal to aperture of the channel  $R_{\max} = a$ , which is determined from Eqs. (3.22) - (3.25) as

$$a = \sqrt{\frac{\varepsilon S}{\mu_o}} \sqrt{b_o + \sqrt{1 + b_o^2}} (1 + \nu_{\max}) \quad (3.26)$$

For negligible beam intensity,  $b_o = 0$ , Eq. (3.26) determines the beam with maximum possible emittance (acceptance of the channel) approximated by envelope equation  $\varepsilon = A_{env}$ :

$$a = \sqrt{\frac{A_{env} S}{\mu_o}} (1 + \nu_{\max}) \quad (3.27)$$

Envelope approximation to acceptance of the channel

$$A_{env} = \frac{a^2 \mu_o}{S (1 + \nu_{\max})^2}$$

The maximum beam current is:

$$I_{\max} = \frac{I_c \mu_o}{2 S} A_{env} (\beta\gamma)^3 \left[ 1 - \left( \frac{\varepsilon}{A_{env}} \right)^2 \right]$$

# Applicability of Smooth Approximation to Beam Dynamics

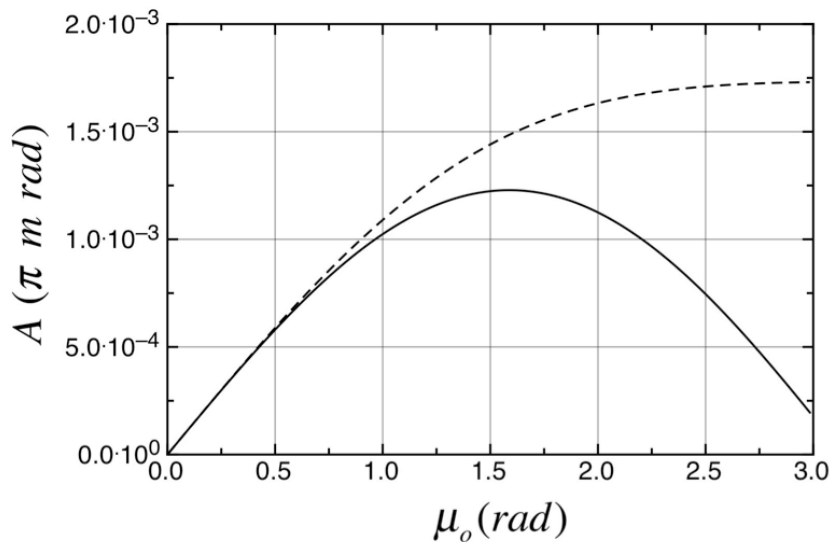
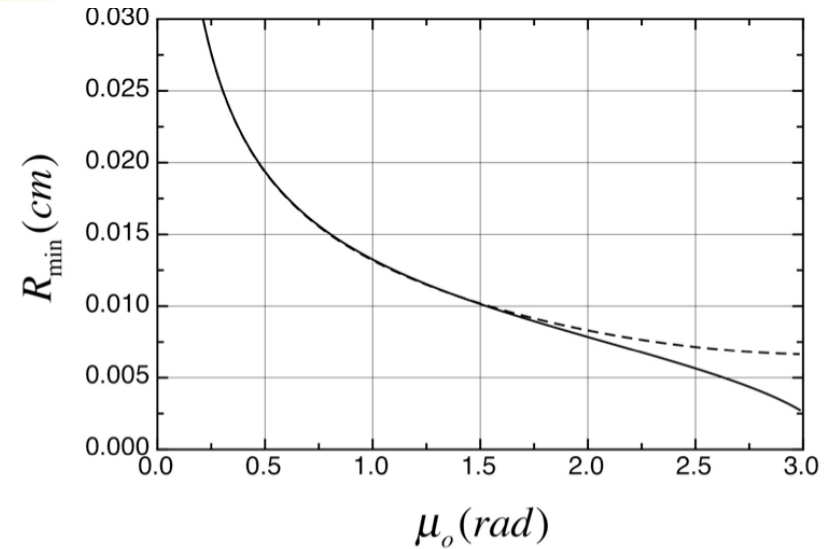
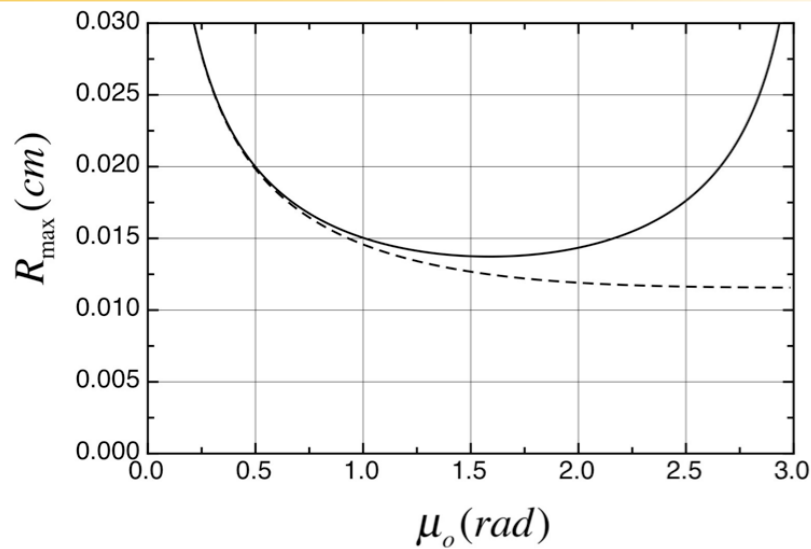

Minimum and maximum beam sizes in periodic solenoid structure with  $D/S=0.034$  (solid line) solution from matrix analysis, (dotted line) smooth approximation to beam envelope.

Fig. 3. Minimum and maximum beam sizes in periodic solenoid structure with  $D/L = 0.034$ : (solid line) solution from matrix analysis, (dotted line) smooth approximation to beam envelope.

# Maximum Transported Beam Current

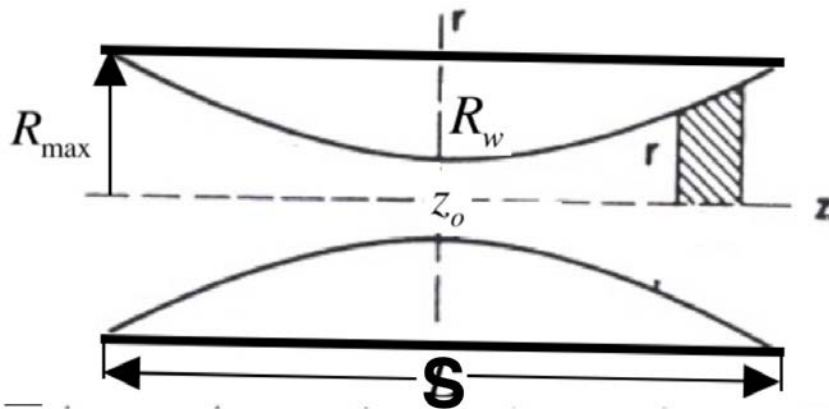

Maximum beam current

$$I_{\text{lim}} = 1.17 I_c (\beta\gamma)^3 \left(\frac{R_{\max}}{S}\right)^2$$

Beam slope after lens

$$\frac{dR}{dz} = \sqrt{\frac{4I_{\text{lim}}}{I_c (\beta\gamma)^3} \ln\left(\frac{R_{\max}}{R_{\min}}\right)} \approx 2 \frac{R_{\max}}{S}$$

On maximum current transported through the tube

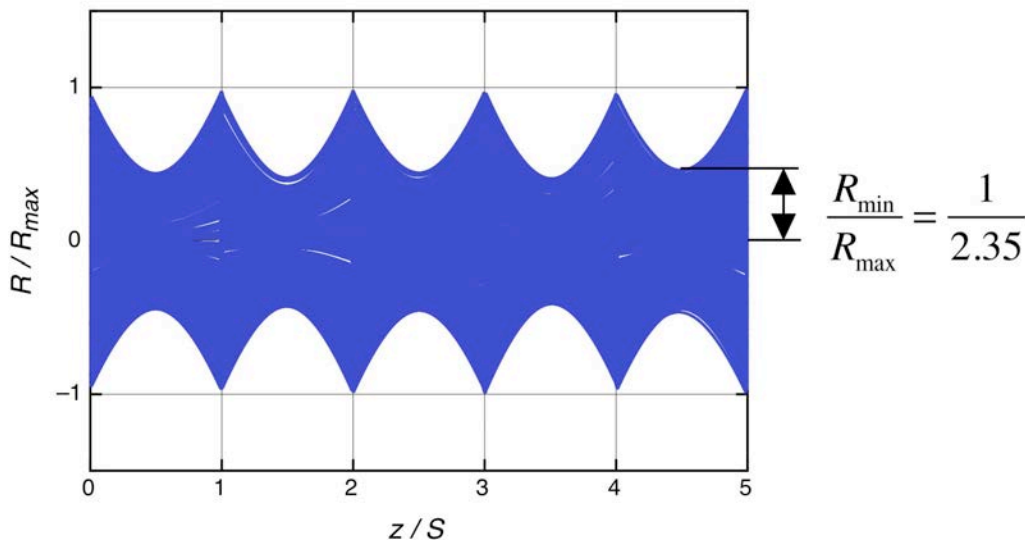

Required focal length  $f \approx \frac{S}{4}$

Matched beam with maximum current in periodic structure of axial-symmetric lenses.



# Spherical Aberration

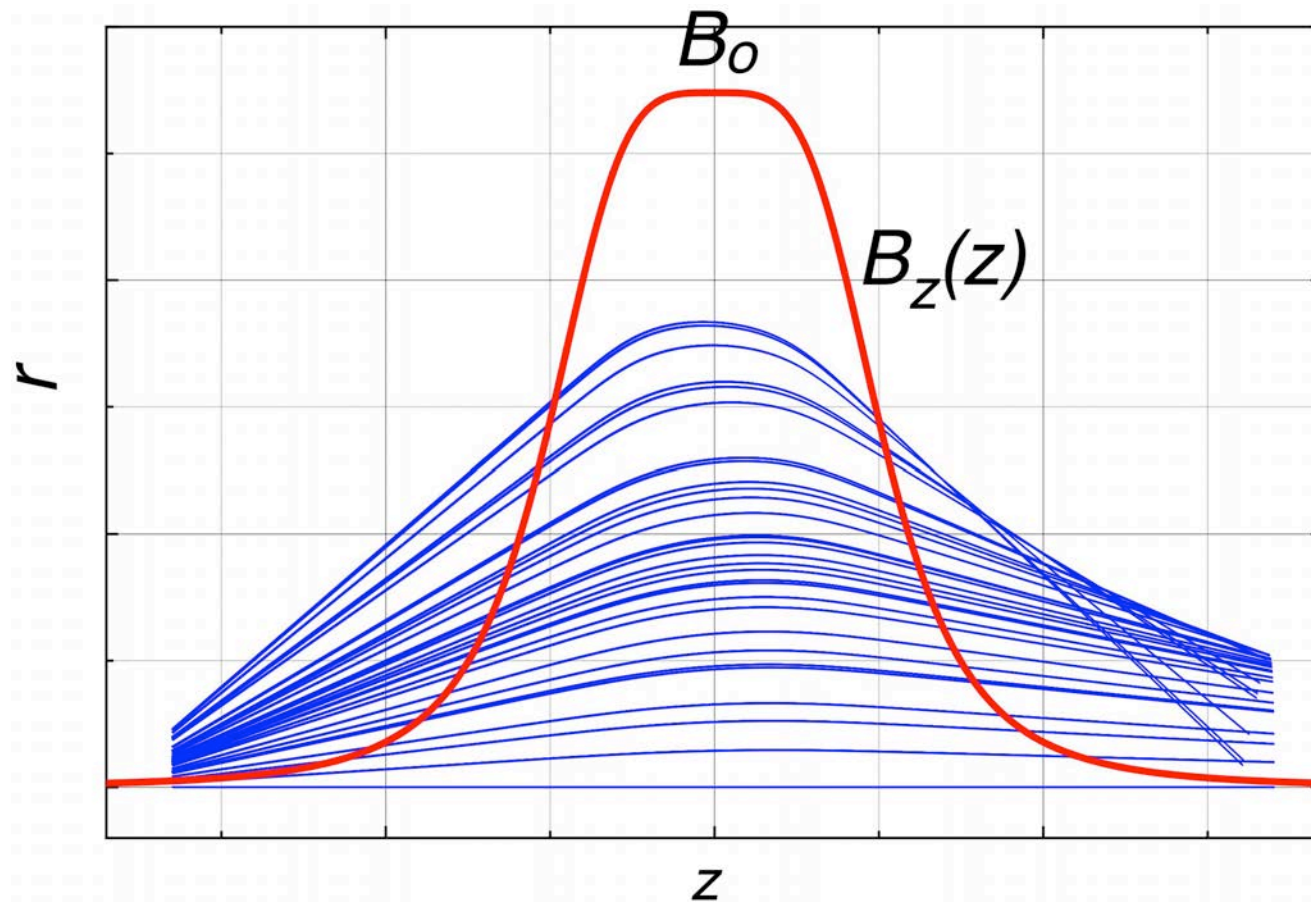

Distortion of particle trajectories after crossing magnetic focusing lens with strong spherical aberration.

# Higher-Order Components of Magnetic Field

Potential of axial-symmetric field

$$U_{magn}(r, z) = \Theta_o(z) - \frac{1}{4} r^2 \Theta_o''(z) + \frac{1}{64} r^4 \Theta_o^{(4)}(z) - \dots$$

Components of magnetic field

$$B_z(r, z) = -\frac{\partial U_{magn}(r, z)}{\partial z}$$

$$B_r(r, z) = -\frac{\partial U_{magn}(r, z)}{\partial r}$$

Magnetic field components can be expressed through longitudinal field component at the axis  $B(z) = -d\Theta_o(z) / dz$  as

$$B_z = \sum_{n=0}^{\infty} \frac{(-1)^n}{(n!)^2} \left(\frac{r}{2}\right)^{2n} B^{(2n)}(z) = B(z) - \frac{r^2}{4} B''(z) + \frac{r^4}{64} B^{(IV)}(z) - \dots$$

$$B_r = \sum_{n=0}^{\infty} \frac{(-1)^{n+1}}{(n+1)(n!)^2} \left(\frac{r}{2}\right)^{2n+1} B^{(2n+1)}(z) = -\frac{r}{2} B'(z) + \frac{r^3}{16} B'''(z) - \dots$$

# Spherical Aberration (cont.)

Equation of motion in a magnetic field

$$\ddot{r} + r \left( \frac{qB_z}{2m\gamma} \right)^2 = 0$$

Magnetic field along the structure

$$B_z(r, z) = B(z) - \frac{r^2}{4} B''(z)$$

Field distribution

$$B(z) = \frac{B_o}{1 + \left(\frac{z}{d}\right)^n}$$

Change in slope of particle trajectory

$$r' = r'_o - r \left( \frac{q}{2mc\beta\gamma} \right)^2 \int_{-\infty}^{\infty} B_z^2 dz$$

$$r' = r'_o - \frac{r}{f} (1 + C_\alpha r^2)$$

Spherical aberration coefficient

$$C_\alpha = -\frac{1}{2} \frac{\int_{-\infty}^{\infty} B(z) B''(z) dz}{\int_{-\infty}^{\infty} B^2(z) dz}$$

$$C_\alpha = \frac{1}{4d^2}, n = 2$$

$$C_\alpha = \frac{5}{12d^2}, n = 4$$

# Focal Length of Solenoid

Focal length of solenoid is given by  $\frac{1}{f} = d \left( \frac{qB_o}{2mc\beta\gamma} \right)^2 \int_{-\infty}^{\infty} \frac{d\xi}{(1 + \xi^n)^2}$

From step-function approximation of the field inside solenoid the focal length is

$$f = \frac{4}{D} \left( \frac{mc\beta\gamma}{qB_o} \right)^2$$

Effective length of solenoid

$$D = d \int \frac{d\xi}{(1 + \xi^n)^2} = \begin{cases} \frac{\pi}{2}d \approx 1.57 d, & n = 2, \\ \frac{3\pi}{4\sqrt{2}}d \approx 1.666 d, & n = 4. \end{cases}$$

# Scherzer Theorem (1936)

Spherical aberrations are unavoidable if

- the lens fields are rotationally symmetric
- the electromagnetic fields are static
- there are no space charges

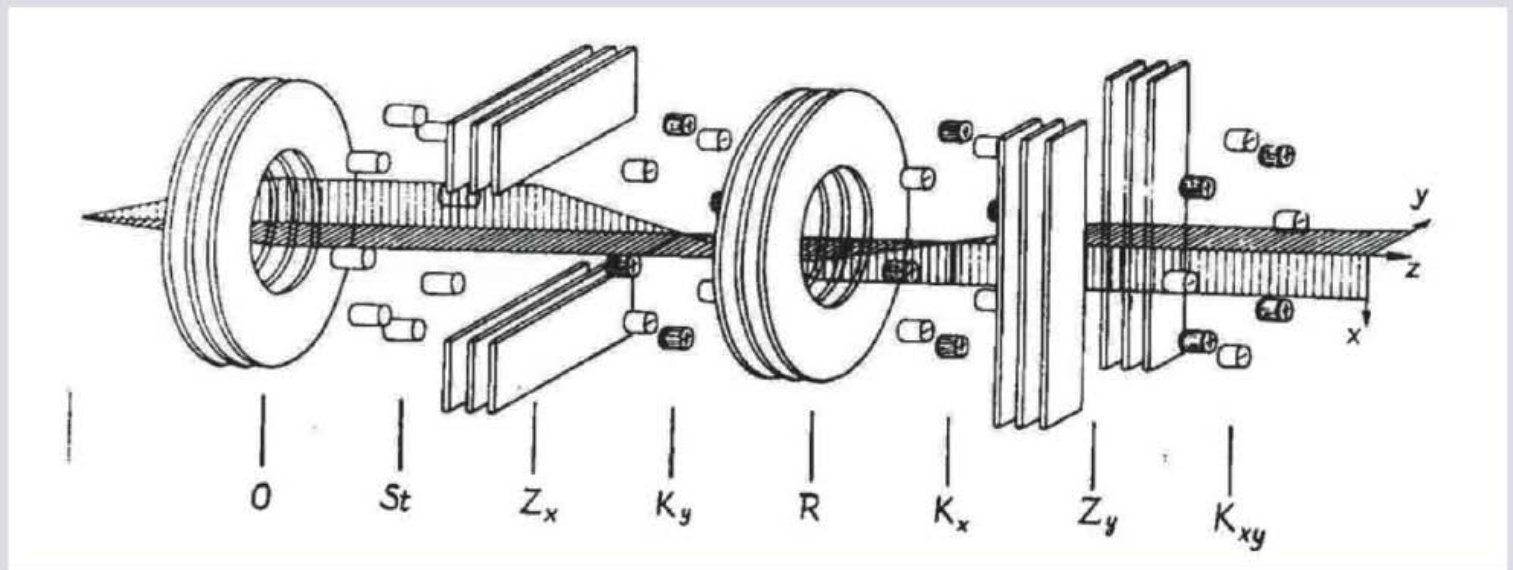

Fig. 7. The Scherzer corrector, as constructed in the 1950s (from Seeliger, 1951): Objective lens (O), stigmator (St), electrostatic cylinder lenses (Z), round lens (R), octopoles (K).

# Beam Emittance Growth due to Spherical Aberrations

Initial beam distribution:

$$\frac{x_o^2}{R^2} \mathfrak{E} + \frac{x_o'^2}{\mathfrak{E}} R^2 = \mathfrak{E}$$

Transformation through the lens

$$x = x_o$$

$$x' = x_o' - \frac{x}{f} (1 + C_\alpha x^2)$$

Change variables  $(x, x')$  to action-angle variables  $(J, \psi)$   $\frac{x\sqrt{\mathfrak{E}}}{R} = \sqrt{2J} \cos \psi$

$$(x' + \frac{x}{f}) \frac{R}{\sqrt{\mathfrak{E}}} = \sqrt{2J} \sin \psi$$

Beam ellipse distortion:  
where

$$T + T^2 2v \sin \psi \cos^3 \psi + T^3 v^2 \cos^6 \psi = 1$$

$$T = \frac{2J}{\mathfrak{E}} \quad v = \frac{C_\alpha R^4}{f \mathfrak{E}}$$

# Beam Emittance Growth due to Spherical Aberrations

$\nu = 0$

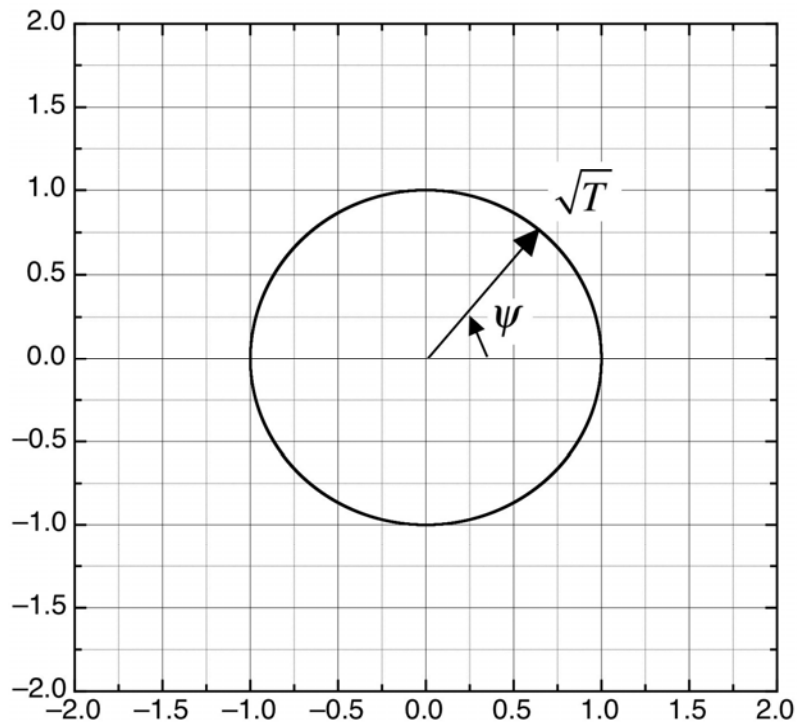

$\nu = 1.6$

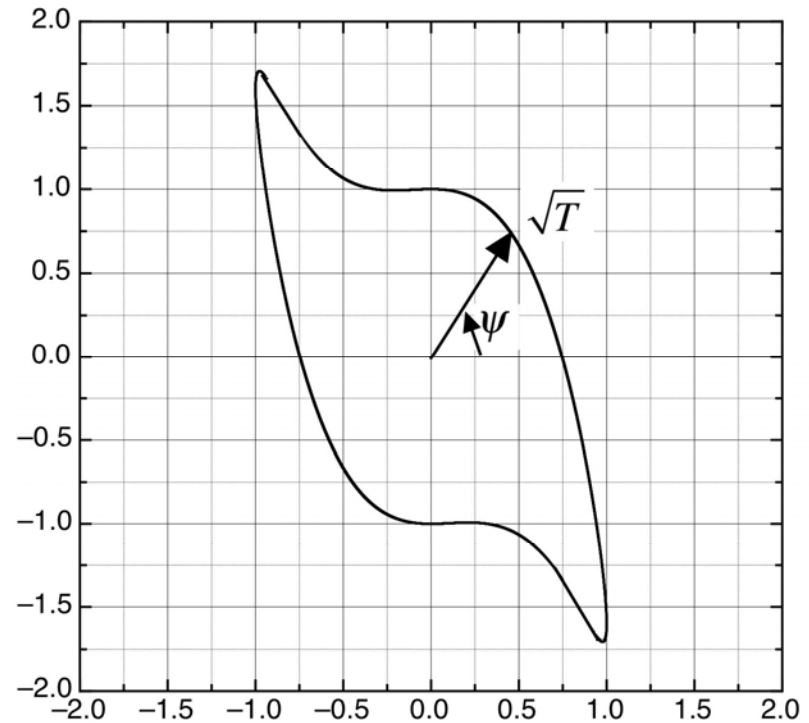

Distortion of beam emittance due to spherical aberration

# Beam Emittance Growth due to Spherical Aberrations

Let us denote the increase of effective beam emittance as a square of product of minimum and maximum values of  $T$ :

$$\frac{\mathfrak{E}_{eff}}{\mathfrak{E}} = \sqrt{T_{max} T_{min}} . \quad (3.22)$$

Values  $T_{max}$ ,  $T_{min}$  are determined numerically. Dependence of emittance growth versus parameter  $\nu$  is presented at figure below. Dependence can be approximated by the function:

$$\frac{\mathfrak{E}_{eff}}{\mathfrak{E}} = \sqrt{1 + K \nu^2} , \quad \nu = \frac{C_\alpha R^4}{f \mathfrak{E}} . \quad (3.23)$$

where parameter  $K \approx 0.4$ . Finally, effective beam emittance growth due to spherical aberrations:

$$\frac{\mathfrak{E}_{eff}}{\mathfrak{E}} = \sqrt{1 + K \left( \frac{C_\alpha R^4}{f \mathfrak{E}} \right)^2} \quad (3.24)$$



# Beam Emittance Growth due to Spherical Aberrations

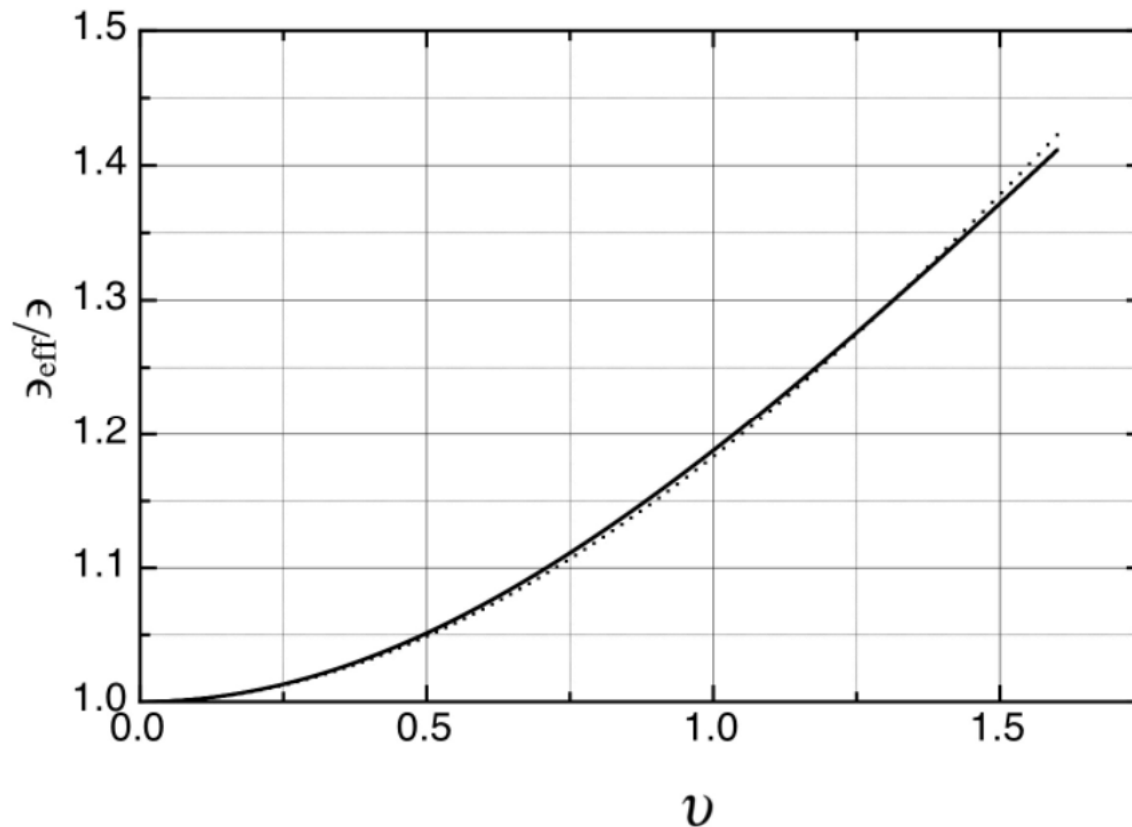

Beam emittance growth after beam passing through axial-symmetric lens as a function of parameter  $\nu$ : (solid line) Eq. (3.22), (dotted line) approximation by Eq.(3.23).

# Emittance Growth due to Spherical Aberrations in Round Beam

Expression for beam emittance growth due to spherical aberrations

$$\frac{\varepsilon_{eff}}{\varepsilon} = \sqrt{1 + K \left( \frac{C_\alpha R^4}{f \varepsilon} \right)^2}$$

was tested numerically for round beam with different particle distributions. As a measure of effective beam emittance, the four-rms beam emittance was used and 2-rms beam size was used as a measure of beam radius:

$$\varepsilon = 4\sqrt{\langle x^2 \rangle \langle x'^2 \rangle - \langle xx' \rangle^2} \quad R = 2\sqrt{\langle x^2 \rangle}$$

Simulations confirm, that dependence is valid for round beam as well, while coefficient  $K$  depends on beam distribution (see Table ). Value of coefficient  $K$  is mostly smaller than that determined above, except that for Gaussian distribution.

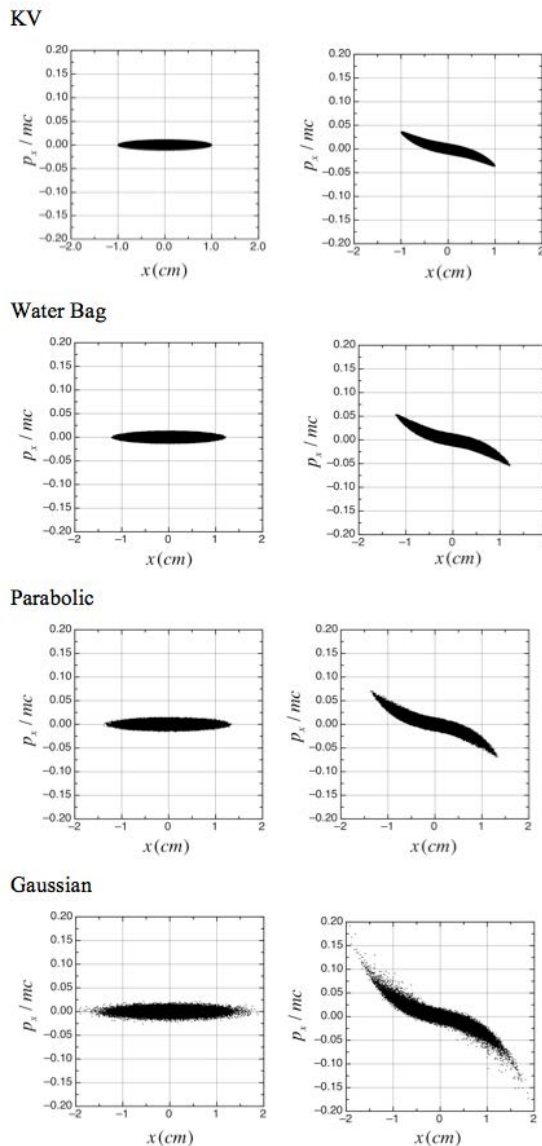

Distribution	Coeff. $K$
KV	0.0556
Water Bag	0.114
Parabolic	0.164
Gaussian	0.541

# Redistribution of Beam Intensity due to Spherical Aberrations

Consider beam of particles parallel to the axis, entering lens. Particle radius after lens is given by:

$$r = r_o \left[ 1 - \frac{z}{f} (1 + C_\alpha r_o^2) \right]$$

where  $z$  is a drift distance from the lens. To find the beam density redistribution, let us take into account that the number of particles  $dN$  inside a thin ring ( $r, r + dr$ ) is kept constant during the drift of the beam at certain distance unless particle trajectories cross each other. Hence, the particle density  $\rho(r) = dN/(2\pi r dr)$  at any  $z$  is connected with the initial density  $\rho(r_o)$  by the equation  $\rho(r) dr^2 = \rho(r_o) dr_o^2$ , or:

$$\rho(r) = \frac{\rho(r_o)}{[1 - \tau (1 + C_\alpha r_o^2)]^2 + \eta^2 - 2 r_o^2 \tau C_\alpha [1 - \tau (1 + C_\alpha r_o^2)]}$$

where  $\tau = z/f$ .

# Redistribution of Beam Intensity due to Spherical Aberrations

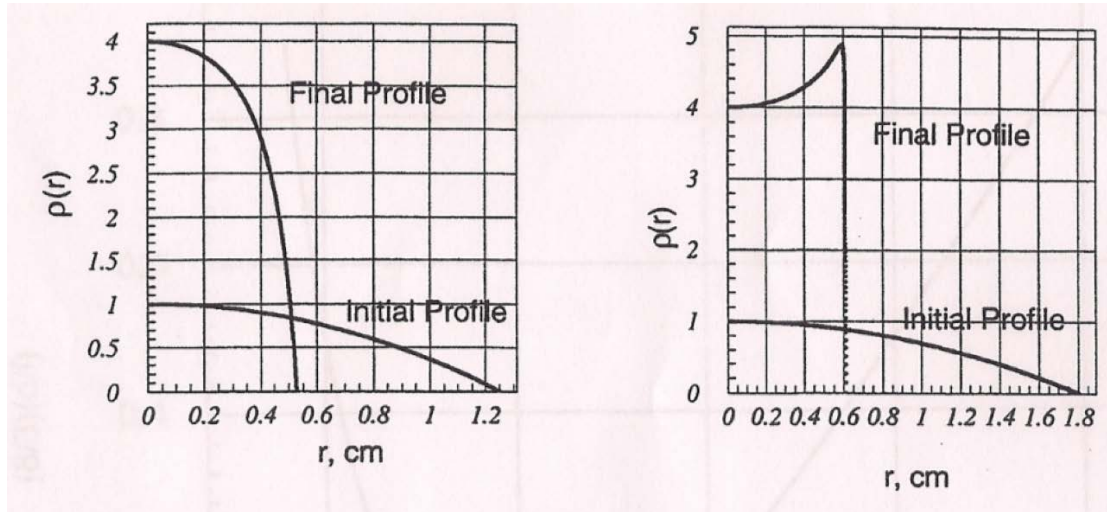

(Left) conservation of beam profile in a lens with linear focusing, and (right) hollow beam formation on a lens with strong nonlinear field.

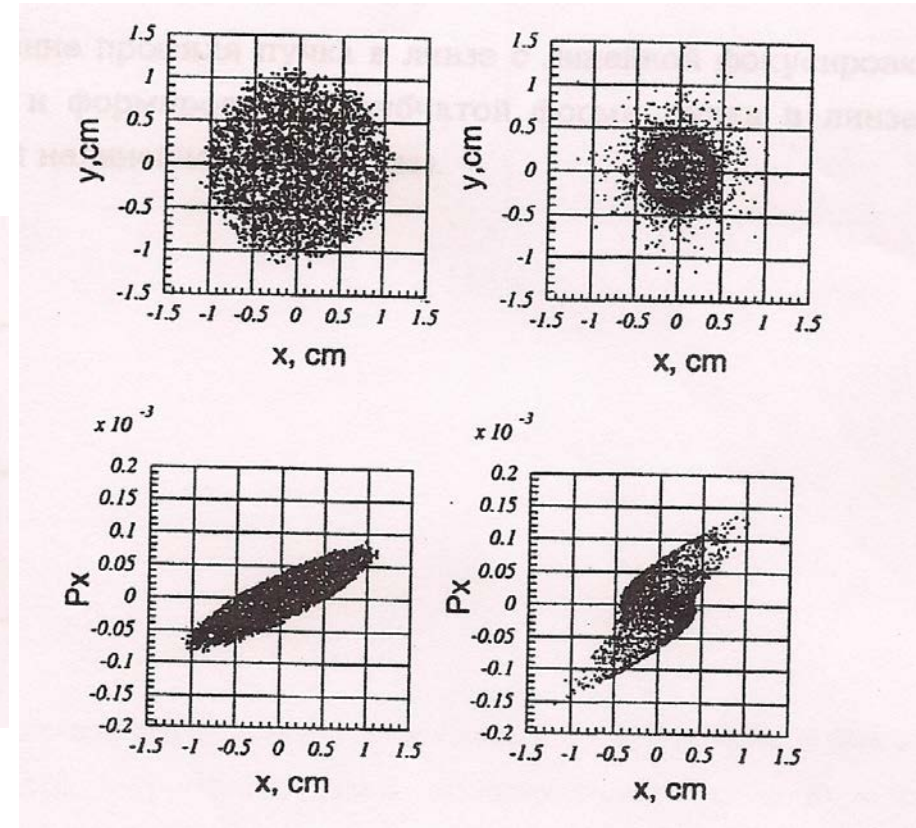

Beam cross sections and phase space distribution before and after crossing the lens with strong nonlinear field.

# Electrostatic Focusing

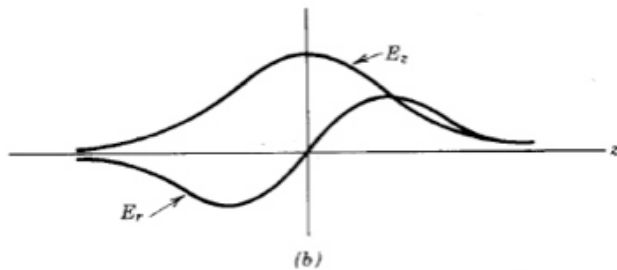
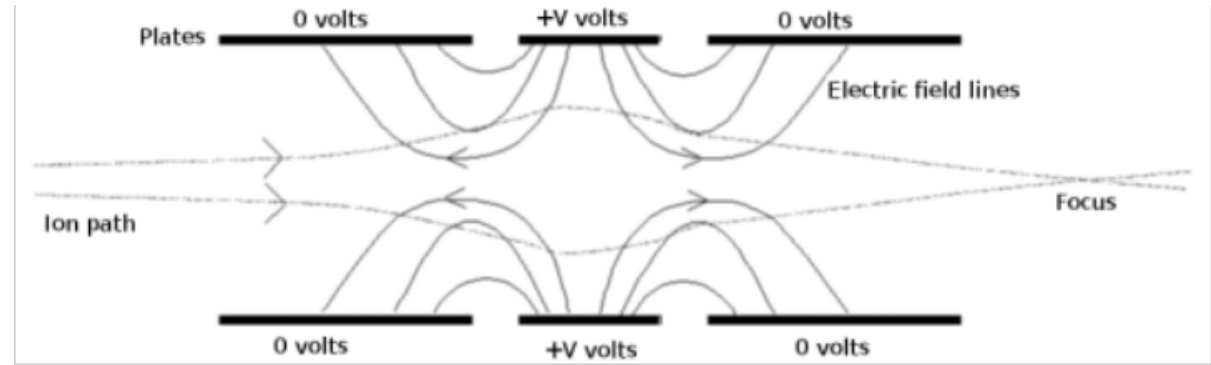
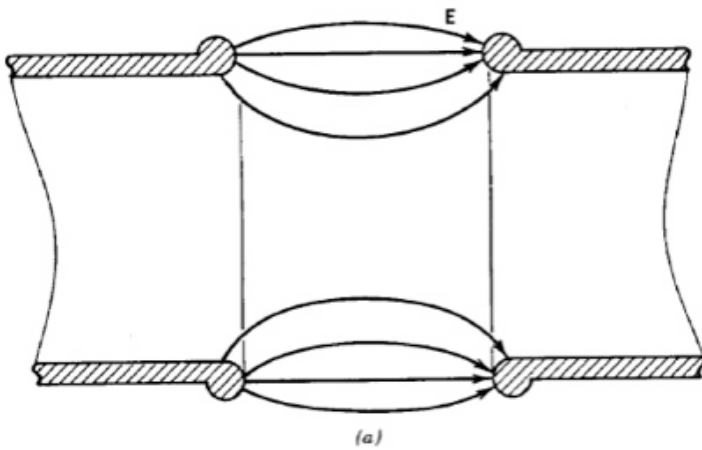

Field distribution in electrostatic lens gap.

Field distribution and particle trajectories in Einzel (equipotential lens).

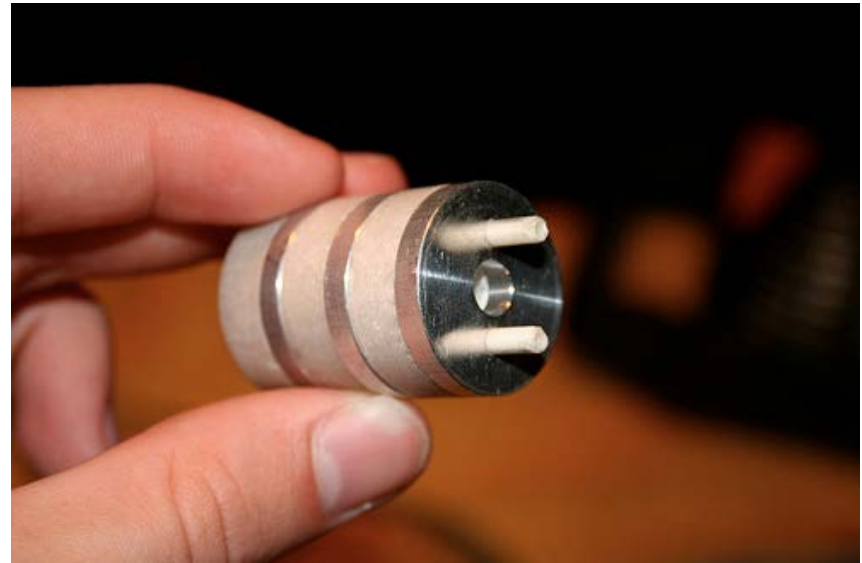

# Potential of Axial-Symmetric Lens

Potential of axial-symmetric electrostatic lens is defined by Laplace's equation:

$$\frac{1}{r} \frac{\partial}{\partial r} \left( r \frac{\partial U}{\partial r} \right) + \frac{\partial^2 U}{\partial z^2} = 0 \quad (3.1)$$

Solution: 
$$U(z, r) = U(z) - \frac{r^2}{4} U''(z) + \frac{r^4}{64} U^{(4)}(z) - \frac{r^6}{2304} U^{(6)}(z) + \dots \quad (3.2)$$

Field distribution inside each gap is given by near-axis approximation:

$$E_z(r, z) = E_z(z) - \frac{r^2}{4} E_z^{(2)}(z) + \frac{r^4}{64} E_z^{(4)}(z) + \dots + \frac{(-1)^n E_z^{(2n)}(z)}{(n!) 2^n} \left(\frac{r}{2}\right)^{2n}, \quad (3.3)$$

$$E_r(r, z) = -\frac{r}{2} E_z'(z) + \frac{r^3}{16} E_z^{(3)}(z) \dots + \frac{(-1)^n E_z^{(2n-1)}(z)}{(n!) (n-1)!} \left(\frac{r}{2}\right)^{2n-1}. \quad (3.4)$$

# Particle Trajectory in Electrostatic Field

Equation of particle motion

$$\frac{d^2 x}{dz^2} = \frac{q}{m v_z^2} x \left( -\frac{1}{2} \frac{\partial E_z}{\partial z} + \frac{r^2}{16} \frac{\partial^3 E_z}{\partial z^3} + \dots \right)$$

Let us neglect the change of particle position in  $x$  - direction while crossing the gap. Change of slope of particle trajectory at the entrance of the first gap is

$$\Delta \left( \frac{dx}{dz} \right)_{in} = \frac{1}{v_{in}^2} \frac{q}{m} x \left( -\frac{1}{2} \int_{-\infty}^{d/2} \frac{dE_z}{dz} dz + \frac{r^2}{16} \int_{-\infty}^{d/2} \frac{d^3 E_z}{dz^3} dz \right) = -\frac{q}{m} \frac{E_z}{2 v_{in}^2} x \left( 1 - \frac{r^2}{8 E_z} \frac{d^2 E_z}{dz^2} \right)$$

where  $v_{in}$  is an effective particle velocity at the entrances of the gap, and the values of the field are taken at the center of the gap. Analogously, the change of the slope of the particle trajectory at the exit of the first gap is

$$\Delta \left( \frac{dx}{dz} \right)_{out} = \frac{q}{m} \frac{E_z}{2 v_{out}^2} x \left( 1 - \frac{r^2}{8 E_z} \frac{d^2 E_z}{dz^2} \right)$$

where  $v_{out}$  is an effective particle velocity at the exit of the first gap. Total change of slope of the particle at the first gap is

$$\Delta \left( \frac{dx}{dz} \right) = \frac{q}{m c^2} \frac{E_z}{2} x \left( \frac{1}{\beta_{out}^2} - \frac{1}{\beta_{in}^2} \right) \left( 1 - \frac{r^2}{8 E_z} \frac{d^2 E_z}{dz^2} \right)$$

# Particle Trajectory in Electrostatic Field

To calculate term in brackets, let us approximate the field in the gap by function

$$E_z = \frac{E_o}{1 + \left(\frac{z}{L}\right)^2}$$

where L is a half of an effective gap width  $L \approx \frac{d+a}{2}$

The second derivative 
$$\frac{d^2 E_z}{dz^2} = -\frac{2E_o}{L^2} \frac{[1 - 3\left(\frac{z}{L}\right)^2]}{[1 + \left(\frac{z}{L}\right)^2]^3}$$

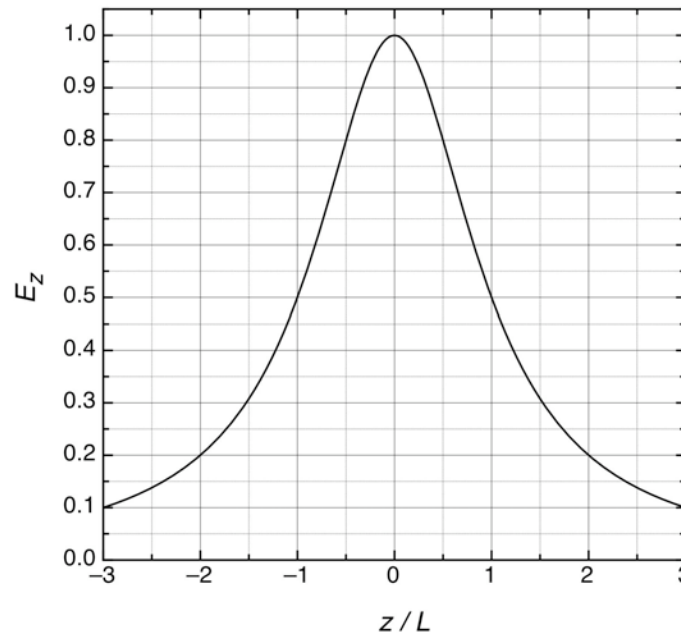

Approximation of the static field in the gap.



# Particle Trajectory in Electrostatic Field

The term in bracket taken at the center of the gap:  $1 - \frac{r^2}{8E_z} \frac{d^2 E_z}{dz^2} = 1 + \frac{r^2}{4L^2}$

Finally, the change of slope of particle trajectory at the gap is

$$\Delta\left(\frac{dx}{dz}\right) = \frac{q}{mc^2} \frac{E_z}{2} \left(\frac{1}{\beta_{out}^2} - \frac{1}{\beta_{in}^2}\right) \left(1 + \frac{x^2}{4L^2}\right) x$$

If the field in the gap accelerates particles,  $E_z > 0$ , then  $\beta_{out} > \beta_{in}$ , and change of slope of particle trajectory is negative  $\Delta\left(\frac{dx}{dz}\right) < 0$

If the field in the gap decelerates particles,  $E_z < 0$ , then  $\beta_{out} < \beta_{in}$ , and change of slope of particle trajectory is also negative  $\Delta\left(\frac{dx}{dz}\right) < 0$

The *gap with electrostatic field focuses particles*. Change of slope of particle trajectory can be written via focal length  $f$  and aberration coefficient  $C_\alpha$ :

$$\Delta\left(\frac{dx}{dz}\right) = -\frac{x}{f} [1 + C_\alpha x^2] \quad C_\alpha = \frac{1}{(2L)^2}$$

# Reduction of Effect of Spherical Aberration in Einzel Lens

Focal length: 
$$\frac{1}{f} = \frac{3}{8d} \left( \frac{\chi^2}{1+\chi} \right)$$

Ratio of potential difference of the lens  $U$  to particle energy  $W$  
$$\chi = U / W$$

Aberration coefficient ( $K = 4...30$ ) 
$$C_\alpha = \frac{K}{R^2}$$

In accelerating gap particles are focusing at the entrance of the lens. Therefore, in lens with accelerating voltage increment of particles radius is negative  $dr < 0$ , while in lens with decelerating voltage  $dr > 0$ . Coefficient of spherical aberration has to be corrected taking into account increment of particle radius inside the gap

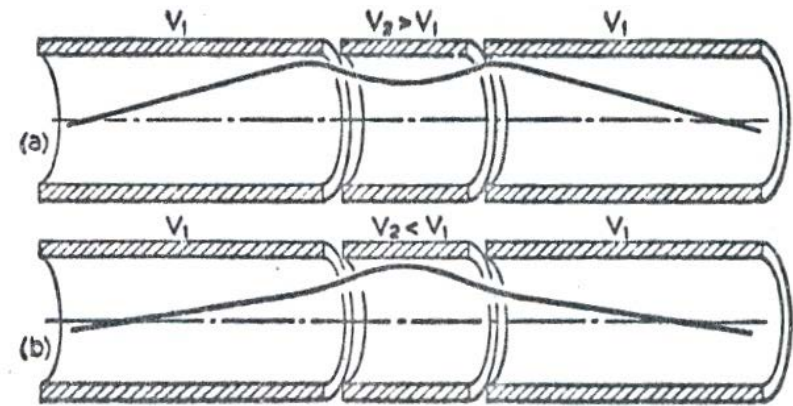

FIG. 6.2—A short cylinder between two cylinders at a different potential forms a converging lens whether the short cylinder is lower or higher in potential than the outer

$$\Delta r_{aberration} = C_\alpha r^3 = C_\alpha (\bar{r} + dr)^3 \approx C_\alpha \bar{r}^3 \left( 1 + 3 \frac{dr}{\bar{r}} \right)$$

$$\bar{C}_\alpha = C_\alpha \left( 1 + 3 \frac{dr}{\bar{r}} \right)$$

Aberration is stronger in decelerating lens than in accelerating lens at the same value of the focal length.